

# Radiola VII

REC. U.S. PAT. OFF.

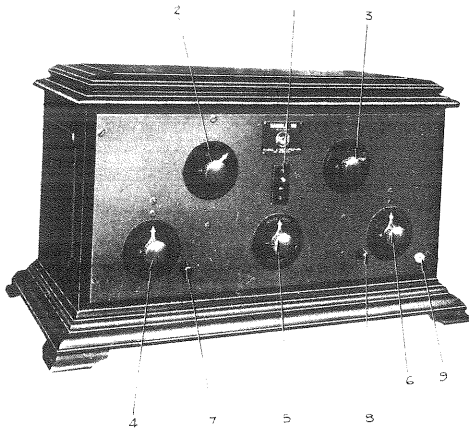

Fig. 1

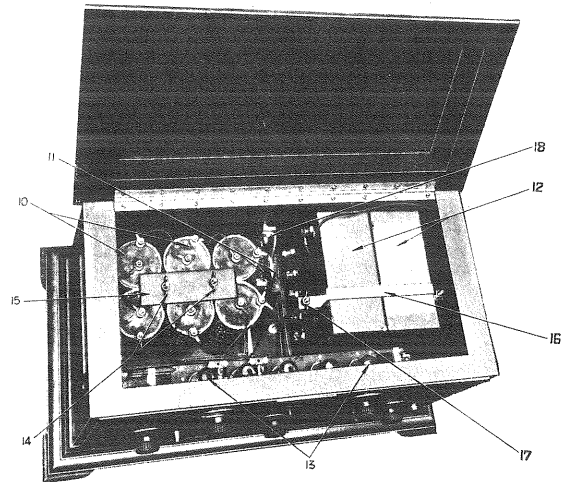

Fig. 2

## INTRODUCTION

Radiola VII is a new type of radio receiver, designed for use with Radiotron UV 199, which operates entirely from dry cells. Electrically, it consists of a highly selective 2-circuit tuner and a 5-tube detector-amplifier, self-contained and ready to connect to antenna and ground (or to a loop antenna), and a loud speaker.

The design is such that all batteries are contained within the cabinet. The wave length range covers the entire broadcasting band of 220 to 550 meters.

Radiola VII may be used with a loop, an indoor antenna or an outdoor antenna. For indoor antenna use, a wire 15 to 20 feet long stretched about the room will give very good results, while for an outdoor antenna a single wire 20 to 180 feet long and 20 to 50 feet in height is the usual practice.

There is included with the set a Faradon socket antenna, which may be substituted in place of an indoor or outdoor antenna. In using the socket antenna, it is only necessary to screw it into a lighting socket in the same manner as an ordinary lamp.

## UNPACKING

Radiola VII is wrapped in wax paper as a protection against dust and moisture, and placed in a corrugated paper carton, which in turn is surrounded by excelsior and contained in the wooden shipping case.

After the receiver is removed from the carton, the lid should be lifted and the accessories which are packed within the receiver removed. The accessories are contained in two packages; one containing 6 UV 199 Radiotrons, 5 being required for the set, and 1 being a spare; and the other containing 1 pair of head telephones, a telephone plug and a Faradon socket antenna.

## BATTERIES REQUIRED

A. Six ordinary dry cells,  $1\frac{1}{2}$  volts each, for lighting the filaments, such as:—

6 Eveready Dry Cell Radio "A" Batteries	( $2\frac{1}{2}$ " x $6\frac{1}{2}$ " ) or,
6 Manhattan Red Seal Dry Cells	( $2\frac{1}{2}$ " x $6\frac{1}{2}$ " ) or,
6 Burgess No. 6 Dry Cells	( $2\frac{1}{2}$ " x 6" ) or,
6 Burgess "Super-Six" Dry Cells	( $2\frac{1}{2}$ " x 6" ) or,
6 Ray-O-Vac No. 1211 Dry Cells	( $2\frac{1}{2}$ " x $6\frac{1}{2}$ " ) or,
6 Ace No. 6 Dry Cells	( $2\frac{1}{2}$ " x $6\frac{1}{2}$ " ) or,
6 Columbia Ignitor No. 6 Dry Cells	( $2\frac{1}{2}$ " x $6\frac{1}{2}$ " )

## OR EQUIVALENT

B. Two 45-Volt Plate Batteries. NOTE: Two 45-Volt Units are recommended instead of Four  $22\frac{1}{2}$ -Volt Units, such as:

2 Eveready No. 767 Plate Batteries	(8" x $6\frac{5}{8}$ " x 3" ) or,
2 Burgess No. 2306 Plate Batteries	( $7\frac{7}{8}$ " x $6\frac{5}{8}$ " x 3" )

## OR EQUIVALENT

C. Two 3-Volt Negative Grid Bias Batteries, such as:  
 2 Eveready No. 750 Flashlight Batteries ( $2\frac{7}{8}'' \times 1\frac{5}{8}'' \times \frac{3}{8}''$ ) or,  
 2 Burgess No. 422 Flashlight Batteries ( $2\frac{1}{4}'' \times 1\frac{1}{4}'' \times \frac{11}{16}''$ ) or,  
 2 Ray-O-Lite No. 421 Flashlight Batteries ( $2\frac{1}{4}'' \times 1\frac{1}{4}'' \times \frac{11}{16}''$ )  
 OR EQUIVALENT

#### INSTALLATION OF BATTERIES

The A Batteries (No. 10, Figure 2) are held in place by the bakelite clamping plate secured by two wing nuts (No. 14 and 15, Figure 2). They should be connected in two parallel groups each of three cells in series, as shown in Figure 3.

The method of connecting the B battery is shown clearly in Figure 4. After the batteries are properly connected, two units should be placed in the cabinet, fastening down with the clamp and wing nut provided (No. 16 and 17, Figure 2). The units should be placed in the cabinet one at a time. The leads are sufficiently long to permit making connections outside the cabinet for convenience.

Great care should be taken to keep the battery connections tight, as failure to do so may result in objectionable noises, or complete inoperation of the set.

To insert the C battery, first bend the long battery prong out straight (to lay parallel to axis of cells). With prongs toward top of cabinet, slip downward into spring (No. 11, Figure 2), then over towards center of box until the prongs are firmly pinched by the small jaws provided for contact. The same instructions apply to the second C battery. The small jaws are placed at different heights in order to properly take the long and short prongs provided on the flashlight batteries.

Be sure that all tubes are removed from their sockets when installing batteries.

#### ADDITIONAL ADJUSTMENTS

If Radiola VII is to be used with an outdoor antenna or with the Faradon socket antenna, the small switch inside the cabinet and back of the C battery support (No. 18, Figure 2) should be down in the open position. If a short indoor antenna is to be used, such as a 20' wire about the room, this switch should be up in the closed position. For long distance work an outdoor antenna is preferable.

In the instance of either an outdoor or indoor antenna being used, a ground connection must be made. This is made preferably to a water pipe, but if this is inconvenient, a radiator or steam pipe

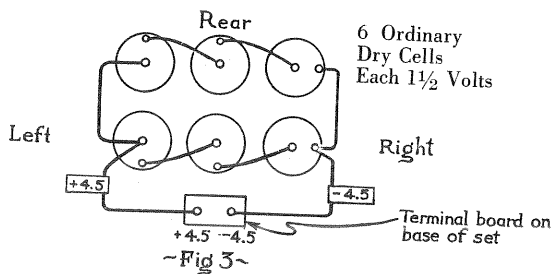
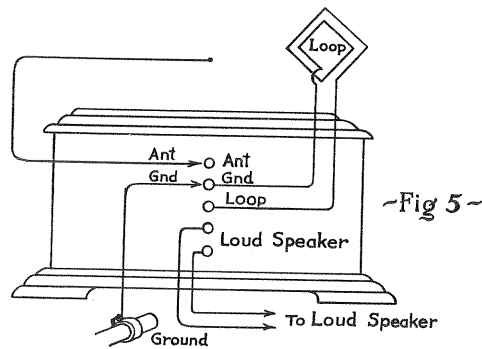
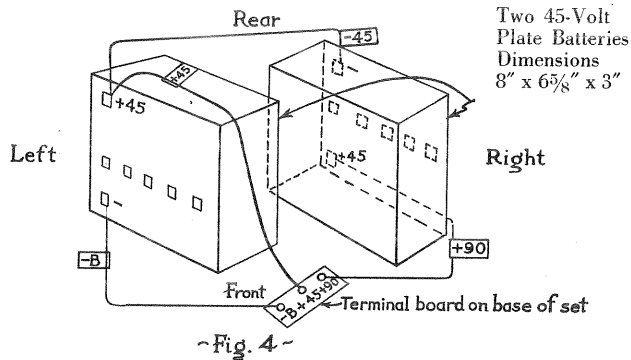

will usually serve the purpose. In making the ground connection, the pipe should be scraped clean and the ground wire firmly connected.

When Radiola VII is used with a loop, no antenna or ground connections are necessary. As shown in Figure 5, the loop connections are the second and third binding posts from the top.

The two binding posts at the bottom of the receiver in the back are for the externally connected loud speaker. Head telephone reception is also possible by connecting the tips of the telephone cord to the plug and plugging in the jack at the lower right corner of the panel. This automatically disconnects the loud speaker. DO NOT attempt to use the loud speaker plugged into the telephone jack, as the volume will be insufficient to operate it. The jack is intended only for head telephones. In connecting the loud speaker, it is well to try reversing the leads, as with some loud speakers this enhances the volume and quality.

The new R. C. A. Loud Speaker, Model UZ-1320 is recommended as being adapted for use with the Radiola VII.

## OPERATION

### WITH OUTDOOR OR INDOOR ANTENNA OR WITH FARADON

#### SOCKET ANTENNA:

1. Be sure that set is properly connected, as per diagrams.
2. Be sure that white button (No. 1, Figure 1) of push switch is out.
3. Insert tubes in their bayonet sockets by pressing down slightly and turning to the right.
4. Adjust Vernier condenser controls (No. 7 and 8) so that white lines will be vertical.
5. Be sure filament control (No. 5, Figure 1) is turned as far as it will go to the left, or opposite to clockwise direction.
6. Press white switch button. This should light the tubes dimly. **CAUTION:** The tubes used in this set burn dimly as compared to the older types of tubes.
7. Advance filament control pointer (No. 5) as far as the word "Increase" on the dial.
8. Place pointer of control (No. 2, Figure 1) in the position on the "Antenna," or upper part of the dial, including the wave length (as marked on the dial) it is desired to receive.
9. Place stabilizer pointer at the maximum position and decrease when "carrier beat" of station desired is heard, as explained below. It should be borne in mind that when two stations of different wave lengths are operating simultaneously, it is usually possible to separate one from the other. This separation can usually be made when stations differ in wave lengths by 10 meters or more, and sometimes when the stations differ by only a few meters, depending upon the skill of the operator. No receiver can separate stations working on exactly the same wave length, although a powerful local station may be easily heard through a weaker and more distant station.
10. With this receiver, when control (No. 2, Figure 1) is on the "antenna" side, seven settings of the "secondary tuning" control for seven different wave lengths are given in the table below:

Dial Setting	Wave Length	Switch Position	Wave Length
	220-280		250
	280-370		300
	" - "		350
	370-460		400
	" - "		450
	460-550		500
	" - "		550

To "pick up" a station, the "second tuning" control should first be set to the approximate wave length of the station it is desired to hear, using the above table for this first setting. Then the "antenna tuning" control (No. 4, Figure 1) should be moved slowly over the scale until signals are heard.

11. When a station is picked up, it should first be carefully adjusted on the Secondary Tuning control, and then on the Antenna Tuning control. Finer adjustment can be made with the two small Vernier knobs No. 7 and No. 8. Signals may be made louder by moving the Stabilizer control toward "increase" until the best adjustment is obtained.

The best stabilizer position will be found at a point just below what is termed the "oscillation point." When the oscillation point is exceeded and secondary control (No. 6, Fig. 1) is moved thru the broadcasting range, whistling sounds known as "carrier beats" will be heard. While receiving a "carrier beat" the procedure is to lower the stabilizer a trifle, at the same time manipulating the secondary vernier (No. 8, Fig. 1) until the carrier beat note disappears indicating that oscillation has ceased and the station is heard without distortion. To strengthen the signal, bring the antenna circuit into tune by varying antenna controls 4 and 7 (Fig. 1). When tuned to maximum intensity by this means gradually increase stabilizer until still further volume is attained. Bear in mind that the stabilizer is an adjustment of sensitivity and not of tuning. Care should be taken that set is not left in oscillating condition.

Increasing the filament current may also help the signal volume, but this control should be kept low as possible to obtain good results, or else the life of the batteries and tubes will be prematurely shortened by the excessive current.

#### WITH LOOP ANTENNA:

1. Place control (No. 2, Figure 1) in the position on the "loop" side including the wave length it is desired to receive.

2. Other precautions and instructions for tuning remain the same as when used with outdoor or indoor antenna, except that the antenna tuning controls (No. 4 and No. 7, Figure 1) are automatically cut out of use, or removed from the circuit.

The Loop should be rotated about its vertical axis until reception reaches a maximum volume. Interference from an undesired transmitter may also be eliminated by making use of the directional properties of the loop, turning it until the undesired signal is weakened as much as possible.

It is advisable when using a loop to remove the antenna and ground leads from the rear binding posts to improve the directional qualities of the loop.

#### CAUTION:

When Radiola VII is not in use the black button of the filament switch should be pushed in to turn off the filaments of the tube. It is detrimental to both tubes and batteries if they are permitted to burn unnecessarily. Handle the tubes carefully and **DO NOT INSERT THEM IN THE SOCKET WHILE THE FILAMENT SWITCH IS ON.**

**NOTE:** Some tubes are better radio frequency amplifiers than others and if several tubes are tried in the second and third sockets from the left it is possible to select the tube combination giving the best results.

#### REPLACEMENTS

Batteries and tubes are the only parts which require replacing.

#### "A" BATTERIES:

With average use these batteries should last about three months. They require replacement when the filament control (No. 5, Fig. 1) must be kept at maximum for best reception, and when the tubes light but dimly with the pointer in that position. The old cells can be removed by disconnecting all wires from battery binding posts

and removing the wing nuts (No. 14, Fig. 2). Then the cells may be taken out and new ones connected in their place. Attached to each lead is a marked metal tag designating to which point the lead is to be connected. Reference to figures 3 and 4 will preclude the possibility of an error in connection and will warrant careful attention. The carbon or center part of a standard dry cell is positive. **DON'T FORGET TO REMOVE TUBES FROM SOCKETS BEFORE REPLACING ANY BATTERIES. NEVER BURN TUBES MORE BRIGHTLY THAN REQUIRED FOR A REASONABLE SIGNAL.**

**"B" BATTERIES:**

The "B" Batteries should outlast two sets of "A" Batteries. It is rather difficult to know when these batteries are exhausted as there is no external indication except weakened signals. The best way is to obtain a voltmeter which will indicate up to 100 volts at least. The meter should show at least 80 volts when across both batteries (new) and batteries are exhausted when total voltage gets below 70 volts.

To replace, remove clamp strip (No. 16, Fig. 2) taking off wing nut (No. 17, Fig. 2) and swinging clamp upward and toward the front of panel. The battery leads are long enough to permit the units to be lifted out onto the cabinet frame, for their disconnection. **DON'T FORGET TO REMOVE TUBES FROM SOCKETS BEFORE REPLACING ANY BATTERIES.** Connect the new units exactly as shown in Fig. 4.

**"C" BATTERIES:**

These cells should be removed every three months to insure proper functioning of Radiola VII. This procedure may be carried out quite readily by reference to the section of this booklet which treats with the installation of the "C" Batteries.

**CARE AND MAINTENANCE**

The cabinet of this receiver is highly finished and it should be treated the same as any piece of fine wood furniture. To keep its original lustre give the cabinet an occasional application of good furniture polish.

Care should be taken in the installation of the antenna and ground to insure good and solid connections. The best method is to clean well with a file and then solder securely. In outside an-

tenna the wire should be kept at least ten feet away from trees and large objects such as roofs or other structures, and must be well insulated on each end and at the lead in. As a precaution never have the antenna wire strung over or under electric light wires as its falling might endanger the set and its operator.

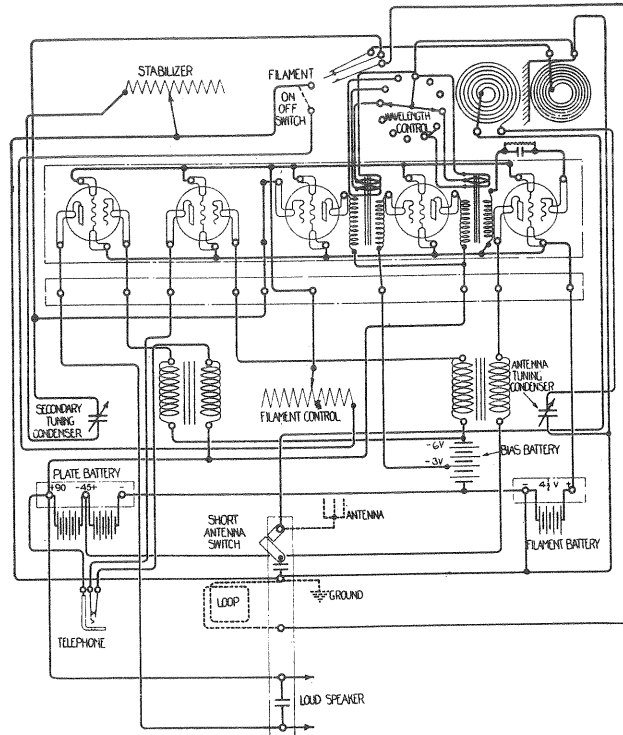

**WIRING DIAGRAM**