

# Service Notes

for

## RCA Victor Portable Victrola Model 2-25

The RCA Victor Portable Victrola Model 2-25 is a small portable type reproducing instrument built into a metal cabinet resembling a small suitcase. Excellent quality, high output and good mechanical construction are features of this instrument.

### LUBRICATION

Premature wear, noisy operation and failure of parts are direct results of failure to clean and lubricate the motor at necessary intervals. The various bearings and gears of the motor should be cleaned and lubricated at least once every six months. In addition to the regular lubrication, all motor parts should be covered with a light film of oil to prevent rusting. Use only RCA Victor Motor Oil and Motor Grease when lubricating this instrument.

**Initial Operation.** When the instrument is first played, wind the motor and allow it to run down completely several times. This insures a complete distribution of lubricant within the spring barrel. Maximum run is dependent on this point.

The speed of the motor should be adjusted so that the turntable revolves at 78 R. P. M. This can be checked by means of a Stroboscope Disc in conjunction with a source of A. C. illumination of proper frequency for the disc used or by counting the revolutions. In both cases a record must be playing in the normal manner when the check is made.

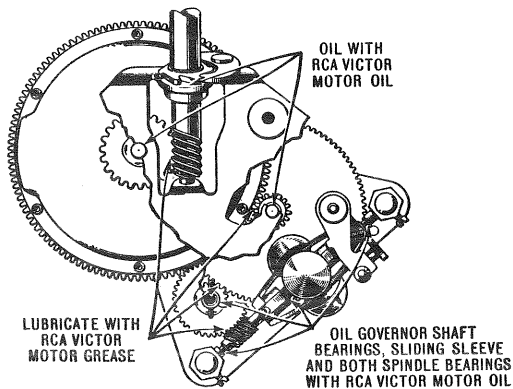

Figure 1—Lubrication Diagram of Model 2-25

**Motor.** Figure 1 shows a view of the motor with the top plate removed. Before lubricating the parts shown in this illustration, a thorough cleaning with carbon tetrachloride (Carbena) or gasoline is necessary. If necessary disassemble the entire motor for such cleaning.

**Tone Arm.** The joint between the taper tube and the sound chamber must be free to swing easily without play and be sealed with grease. This bearing is accessible when the three mounting screws are removed. Failure to seal this joint will result in poor quality. Unnecessary friction will cause undue record wear.

### MOTOR

The motor used in Model 2-25 is of simple design and will give excellent performance. If kept clean and properly lubricated, little service attention will be required. The

following points may prove useful when it is necessary to effect repairs. *Before doing any work on the motor the machine must be allowed to run down completely.*

**Removing Motor from Cabinet.** To remove the motor from the cabinet proceed as follows:

- (a) Unscrew the spindle cap and remove the turntable.
- (b) Remove the four machine screws that hold the motor in place. The motor may then be removed through the hole in the motor board.

**Changing Motor Springs.** Should a spring break and require replacement the best method to make a repair is to replace the entire spring barrel. While the cost of the spring barrel is greater than that of the spring alone, the saving in labor will usually justify such replacement. Unless the serviceman is experienced in handling springs of this type, the following directions should be followed carefully:

- (a) Disassemble the motor and remove the spring barrel. Remove the winding gear.
- (b) Place the gear flat on a piece of metal and file off the ends of the six rivets. Remove the rivets and gear.
- (c) Place the palm of the right hand over the closed end of the barrel, making sure that the fingers do not protrude beyond the open side. Firmly hold the barrel, open side downward over a large can or barrel. With the left hand pull the center turns of the spring out. As soon as the spring starts, pull the left hand clear of the can holding the spring barrel firmly until the spring is entirely clear.
- (d) A new coiled spring may prove extremely dangerous if not properly handled. Read these instructions and work very carefully especially if not experienced in work of this kind. The new spring is furnished coiled and with a heavy wire clamp holding the spring tightly wound. Pull out about one foot of the spring. Then with the spring flat on a table gently tap the ring until it comes to the edge. Do not push the clamp so close to the edge that it will not hold the spring.

Place the hook end of the spring over the barrel hook. Wind the exposed end into the barrel and then insert the entire spring in the barrel allowing the clamp to be on the outer edge. Place a block over the entire spring and force the spring into the barrel thereby releasing the clamp.

- (f) Place a tablespoonful of spring lubricant between the spring leaves and in the center of the spring.
- (g) Place the gear in position and rivet it with six rivets to the spring barrel. Use a small punch for flattening the ends of the rivets. Place the gear on a flat surface while re-riveting the barrel to it.
- (h) Reassemble the motor in the reverse manner of that used to dismantle it.

**Winding Shaft Binding.** A heavy jar may cause the motor to shift slightly on the motor board and produce binding of the winding shaft against the motor board. Loosening the motor mounting screws and shifting the motor to its proper position will correct this condition.

# REPLACEMENT PARTS

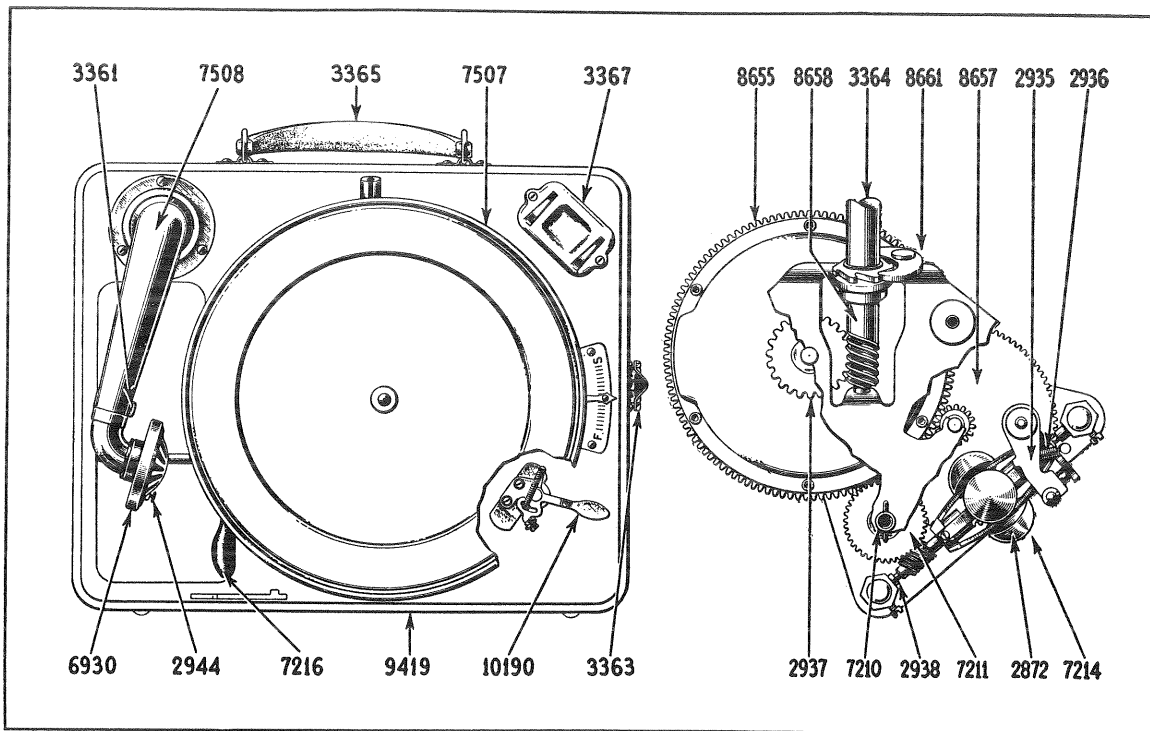

Figure 2—Cabinet, Motor Board and Motor Parts

Stock No.	DESCRIPTION	List Price	Stock No.	DESCRIPTION	List Price
2872	Governor ball and spring assembly—Comprising ball, spring, mounting screws and washers—Package of 5....	\$0.75	7211	Gear—Turntable spindle gear complete with set screw.....	\$0.50
2935	Lever—Speed regulator lever complete with stud and spring—Package of 2..	.50	7214	Governor assembly—Comprising governor spindle, disc, collar, governor balls and springs.....	2.50
2936	Spring—Speed regulator lever spring—Package of 10.....	.50	7216	Key—Winding key.....	1.00
2937	Gear—Winding gear and sleeve.....	.90	7226	RCA Victor motor oil—1 pint can.....	.50
2943	Cap—Turntable spindle cap screw—Package of 5.....	1.50	7227	RCA Victor motor grease—1 pint can..	.60
2944	Screw—Sound box needle screw—Package of 20.....	1.00	7228	RCA Victor spring lubricant—1 pint can.....	.65
2947	Leather—Friction leather for brake—Package of 20.....	.50	7447	Plate—Top plate assembly comprising top and bottom plates complete.....	3.00
3361	Hook—Tone arm and crank hook.....	.65	7507	Turntable—Complete with covering...	2.90
3362	Hinge—Cabinet hinge with mounting screws—Package of 2.....	.60	7508	Tube—Taper tube with pivot pin—Less sound box—Used with sound box No. 6930.....	2.20
3363	Lock—Lid lock with mounting screws..	.90	8655	Barrel—Spring barrel complete with main spring and driving gear—Less winding gear.....	3.00
3364	Extension—Winding shaft extension...	.70	8656	Spring—Main spring.....	1.15
3365	Handle—Carrying handle complete with bracket and mounting rivets.....	.90	8657	Gear—Intermediate gear complete with pinion and shaft.....	.70
3366	Scale—Speed regulator scale complete with mounting screws.....	.50	8658	Shaft—Winding shaft—Comprising shaft, collar, pin, ratchet and washer—Less winding extension.....	1.25
3367	Holder—Needle holder.....	.75	8661	Motor—Motor complete with spindle cap.....	12.00
6930	Sound box—Complete with needle screw.....	4.50	9419	Cabinet complete—Less mechanism...	Price on application
7210	Spindle—Turntable spindle complete with pins and ball bearing—Less gear	.80	10190	Brake—Turntable hand brake—Package of 2.....	

Service Division RCA Victor Company, Inc., Camden, N. J.

# Service Notes for RCA Victor Portable Victrola Model 2-65

The RCA Victor Portable Victrola Model 2-65 is a small portable type instrument built into a cabinet resembling a small suitcase. Excellent quality, high output and good mechanical construction are features of this instrument.

## LUBRICATION

Premature wear, noisy operation and failure of parts are direct results of failure to clean and lubricate the motor at necessary intervals. The various bearings and gears of the motor should be cleaned and lubricated at least once every six months. In addition to the regular lubrication, all parts should be covered with a light film of oil to prevent rusting. Use only RCA Victor Motor Oil and Motor Grease when lubricating this instrument.

**Initial Operation.** When the instrument is first played, wind the motor and allow it to run down *completely* several times. This insures a complete distribution of lubricant within the spring barrel. Maximum run is dependent on this point.

The speed of the motor should be adjusted so that the turntable revolves at 78 R.P.M. This can be checked by means of a Stroboscope Disc in conjunction with a source of A.C. illumination of proper frequency for the disc used or by counting the revolutions. In both cases a Record must be playing in the normal manner when the check is made.

**Motor.** Figure 1 shows a view of the motor with the top plate removed. Before lubricating the parts shown in this illustration, a thorough cleaning with carbon tetra-chloride (Carbena) or gasoline is necessary. If necessary disassemble the entire motor for such cleaning.

**Tone Arm.** The joint between the goose neck and tone arm and that between the tone arm and sound chamber must be free to swing easily without play and be sealed with grease. The goose neck is detached or adjusted by means of two collars that hold it in place. The bearing between the tone arm and sound box is accessible when the swivel and three mounting screws are removed. Failure to seal these joints will result in poor quality. Unnecessary friction at either of these points will cause undue record wear.

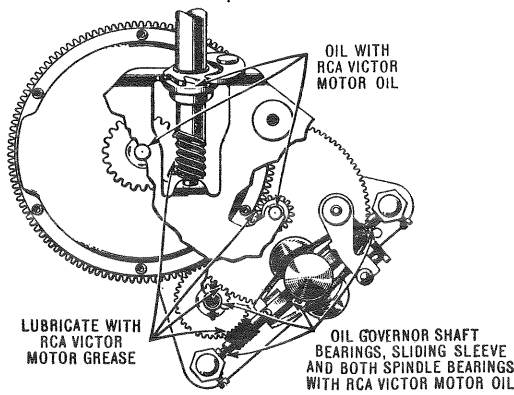

Figure 1—Lubrication Diagram of Model 2-65

## AUTOMATIC STOP MECHANISM

The Automatic Stop Mechanism is simple of design and effective in operation. Figure 2 shows its principal parts.

**Failure to Start.** Should pulling the tone arm to the right and then placing the sound box on the record fail to start the motor, it may be due to:

- (a) Improper location of base plate. Loosen the screws A, B, and C and shift position of mechanism counter-clockwise until proper operation is secured.
- (b) Worn or rounded surfaces at point D. Square these points with a small file.
- (c) Insufficient tension at spring E. Remove a few turns or replace spring.

**Failure to Trip.** Should the mechanism fail to stop the motor at the end of a Victor record having the eccentric groove, check the following:

- (a) Improperly adjusted base plate. Loosen screws A, B, and C and shift the mechanism clockwise until proper operation is obtained.
- (b) Loose or improperly adjusted latch plate.
- (c) Insufficient tension at spring F. Remove several turns or replace spring.

**Tripping during Operation.** Premature tripping during the operation of a record may be caused by:

- (a) Binding at bearing G. Clean and lubricate this bearing.
- (b) Insufficient bite at point D. Loosen the screws A, B, and C and adjust the base plate so that a larger bite is obtained at point D.

## MOTOR

The motor used in Model 2-65 is of simple design and will give excellent performance. If kept clean and properly lubricated, little service attention will be required. The following points may prove useful when it is necessary to effect repairs.

**Removing Motor from Cabinet.** To remove the motor from the cabinet proceed as follows:

- (a) Unscrew the spindle cap and remove the turntable.
- (b) Remove the eight machine screws that hold the motor board in place. The sound deflector is also removed.
- (c) Remove the three motor mounting screws, together with the one holding the speed regulator lever. Remove this lever. The motor board may now be turned over and the motor pulled clear and placed in a position convenient for work. The various parts are

easy of access and adjustments or replacements are simple to make.

**Changing Motor Springs.** Should a spring break and require replacement the best method to make a repair is to replace the entire spring barrel. While the cost of the spring barrel is greater than that of the spring alone, the saving in labor will usually justify such replacement. Unless the serviceman is experienced in handling springs of this type, the following directions should be followed carefully:

- (a) Disassemble the motor and remove the spring barrel. Remove the winding gear.
- (b) Place the gear flat on a piece of metal and file off the ends of the six rivets. Remove the rivets and gear.
- (c) Place the palm of the right hand over the closed end of the barrel, making sure that the fingers do not protrude beyond the open side. Firmly hold the barrel, open side downward over a large can or barrel. With the left hand pull the

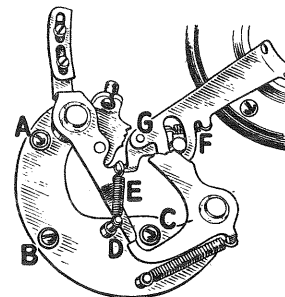

Figure 2—Automatic Stop Mechanism

center turns of the spring out. As soon as the spring starts, pull the left hand clear of the can holding the spring barrel firmly until the spring is entirely clear.

(d) The new spring is furnished coiled and with a heavy wire clamp. Hit the spring flat on a table thereby driving the clamp to one edge of the spring. Grasp the exposed part of the spring firmly with the right hand and pull the clamp off with the left hand. Allow the spring to gradually release its tension in the right hand and then unwind it completely.

(e) Place the hooked end of the spring over the barrel hook and wind the spring into the barrel toward the center. Be careful to push each turn completely inside the barrel before winding on the next turn.

(f) Place a tablespoonful of spring lubricant between the spring leaves and in the center of the spring.

(g) Place the gear in position and rivet it with six rivets to the spring barrel. Use a small punch for flattening the ends of the rivets. Place the gear on a flat surface while re-riveting the barrel to it.

(h) Reassemble the motor in the reverse manner of that used to dismantle it.

**Winding Shaft Binding.** A heavy jar may cause the motor to shift slightly on the motor board and produce binding of the winding shaft against the motor board. Loosening the motor mounting screws and shifting the motor to its proper position will correct this condition.

# REPLACEMENT PARTS

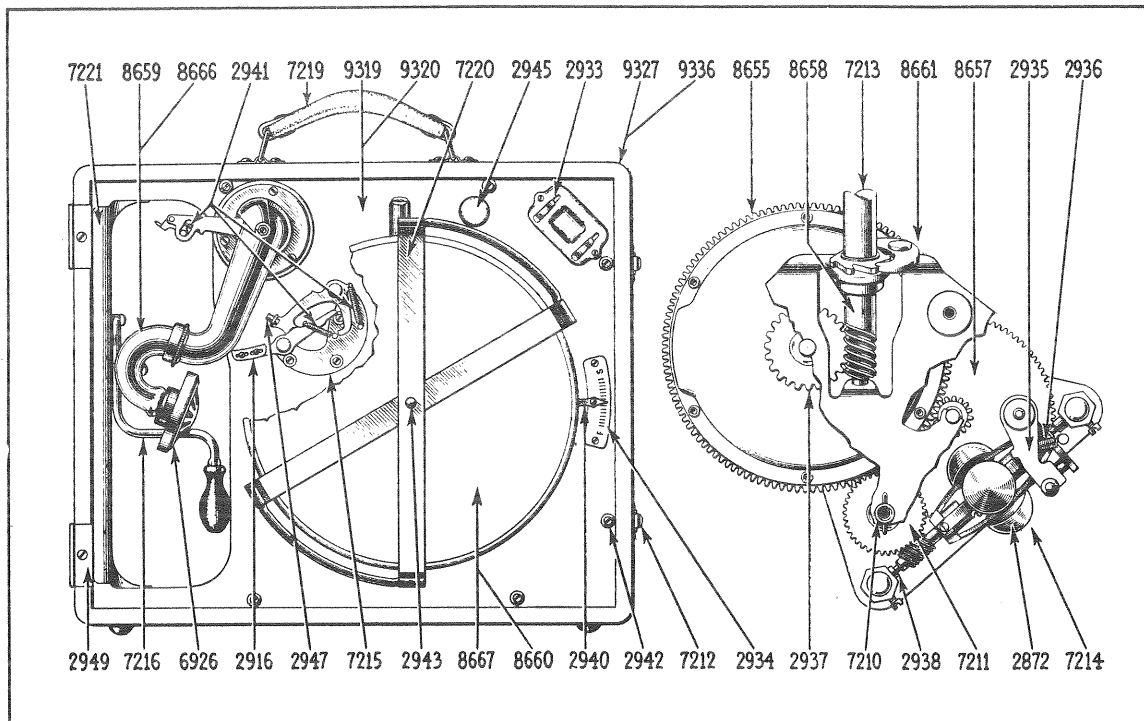

Figure 3—Cabinet, Motor Board and Motor Parts

STOCK NO.	DESCRIPTION	LIST PRICE	STOCK NO.	DESCRIPTION	LIST PRICE
2872	Governor Ball and Spring—Governor ball and spring assembly comprising ball, spring, mounting screws and washers—Package of 5 .....	\$0.75	7216	Key—Winding Key .....	\$1.00
2916	Plate—Latch Plate complete with mounting screws—Package of 5 .....	.60	7219	Handle—Carrying Handle complete with bracket and mounting rivets .....	1.00
2933	Holder—Needle Holder complete with mounting screw—Package of 2 .....	.80	7226	RCA Victor Motor Oil—1 pint can .....	.50
2935	Lever—Speed Regulator Lever complete with stud and spring—Package of 2 .....	.50	7227	RCA Victor Motor Grease—1 pint can .....	.60
2936	Spring—Speed Regulator Lever Spring—Package of 10 .....	.50	7228	RCA Victor Spring Lubricant—1 pint can .....	.65
2937	Gear—Winding Gear and sleeve .....	.90	8655	Barrel—Spring Barrel complete with mainspring and driving gear—less winding gear .....	3.00
2938	Governor Bearing Assembly—Governor bearing, comprising 2 bearings, 2 set screws and 2 balls—Package of 3 sets .....	.50	8656	Spring—Mainspring—Not illustrated .....	1.15
2939	Screw—Motor Mounting Screw complete with washer—Package of 2 sets—Not illustrated .....	.50	8657	Gear—Intermediate Gear complete with pinion and shaft .....	.70
2940	Lever—Speed Regulator Lever complete with springs, washers and nut—Package of 2 .....	.60	8658	Shaft—Winding Shaft, comprising shaft, collar, pin, ratchet and washer—less winding extension .....	1.25
2941	Spring—Automatic Brake Springs—one set of 3 springs .....	.50	SPECIAL PARTS SUPPLIED ON ORDER ONLY (NOT TO BE STOCKED)		
2942	Screws—Motor Board Mounting Screws complete with finishing washers—Package of 10 .....	.60	2934	Scale—Speed Regulator Scale complete with mounting screw—Package of 5 .....	.50
2943	Cap—Turntable spindle cap screw—Package of 5 .....	1.50	2949	Hinge—One set of 2 hinges complete with mounting screws and rivets .....	.50
2944	Screw—Sound Box Needle Screw—Package of 20—Not illustrated .....	1.00	6926	Sound Box—Sound Box complete with needle screw .....	4.50
2945	Rest—Rubber Needle Rest—Package of 5 .....	.50	7218	Support—Lid Support with mounting screws, package of 2—Not illustrated .....	.50
2947	Leather—Friction Leather for Brake—Package of 20 .....	.50	7220	Tray—Record Carrying Tray .....	.75
2948	Rivet—Driving Gear Rivet—Package of 100 .....	.50	7221	Deflector—Sound Deflector .....	1.50
7210	Spindle—Turntable Spindle complete with Pin and Ball Bearing—less gear .....	.80	8659	Tube—Taper tube complete with goose neck and mounting screw—less sound box—Blue .....	7.00
7211	Gear—Turntable Spindle Gear complete with set screw .....	.50	8660	Turntable—Turntable complete with covering—Blue .....	2.50
7212	Catch—Cabinet Catch, two pieces, complete with mounting rivets—Package of 2 .....	1.00	8661	Motor—Spring motor complete with spindle cap screw—less mounting screws .....	12.00
7213	Extension—Winding Shaft Extension .....	.60	8666	Tube—Taper Tube complete with goose neck and mounting screw—less sound box—Red .....	7.00
7214	Governor Assembly—Governor Assembly, comprising governor spindle, disc, collar, governor balls and springs .....	2.50	8667	Turntable—Turntable complete with covering—Red .....	2.50
7215	Brake—Automatic Brake complete with mounting screws .....	1.25	9319	Board—Motor Board—Blue .....	5.50
			9320	Board—Motor Board—Red .....	5.50
			9327	Cabinet—Cabinet complete with handle and catches—less motor board—Blue .....	12.50
			9336	Cabinet—Cabinet complete with handle and catches—less motor board—Red .....	12.50

**Service Division RCA Victor Company, Inc. Camden, N.J.**