



Amateur Communications Receiver

(For A-C Power Supply)

Model ACR-136

OPERATING INSTRUCTIONS
AND
SERVICE NOTES

"All-Wave" Range
540 to 18000 Kilocycles

AMATEUR RADIO SECTION

RCA Victor Division

RCA Manufacturing Company, Inc.

Camden, N. J., U. S. A.

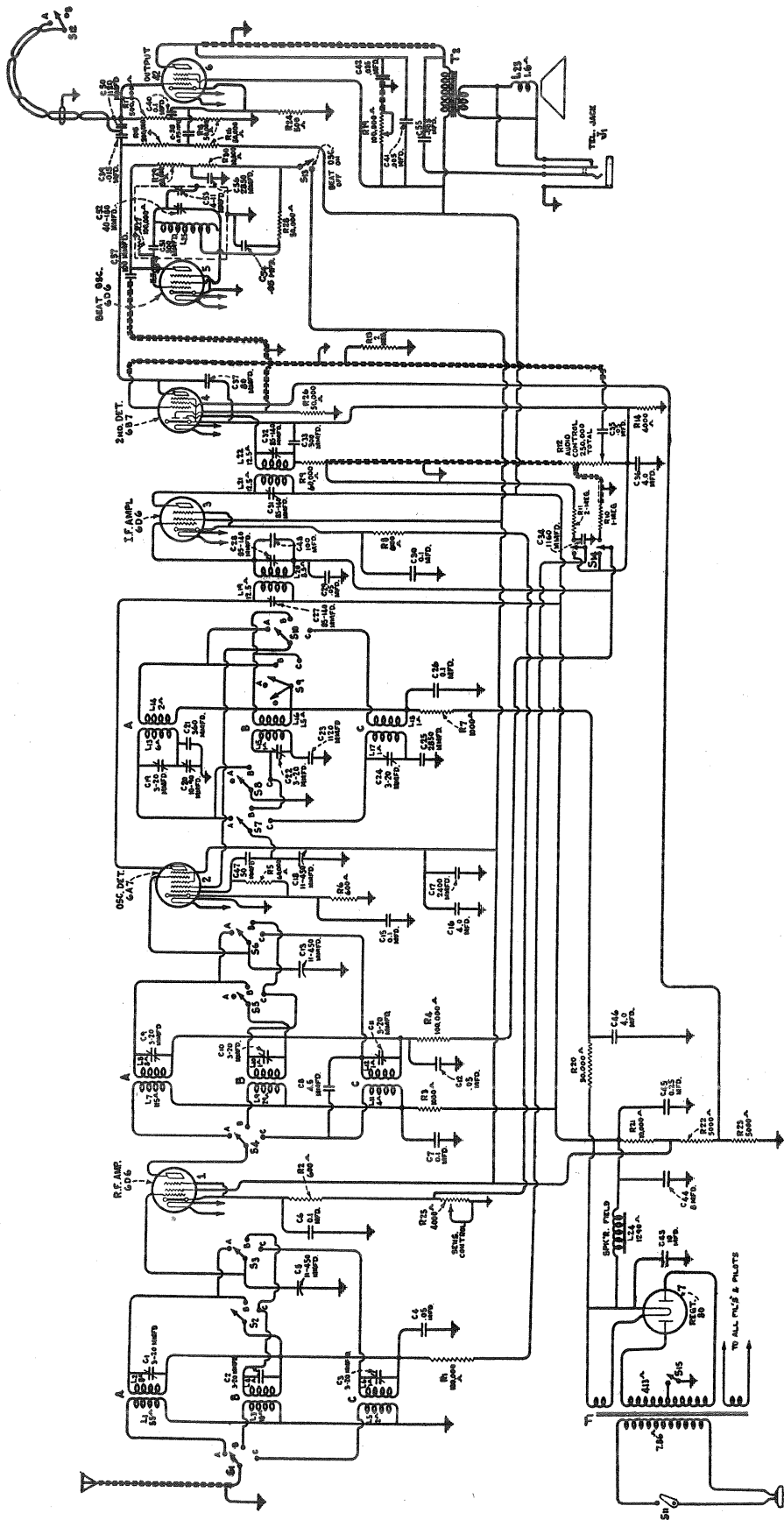

Figure 1—Schematic Circuit Diagram

Amateur Communications Receiver

Seven-Tube, Three-Band A-C Superheterodyne

Important—(Installation Notice)

The chassis of this receiver is flexibly mounted on rubber cushions, but for shipment is clamped rigidly to the instrument case. At installation, loosen the four screws on bottom of case, remove the metal clamp from beneath each screw and re-tighten sufficiently to compress each adjacent rubber cushion approximately one-eighth inch.

Part I

OPERATING INSTRUCTIONS

Electrical Specifications

Circuit—Superheterodyne with beat-frequency oscillator for C-W reception, automatic volume control and pentode output stage.

Tuning Range—540 to 18000 kilocycles, as follows:

Band	Limits (kc.)	Services
A	540-1720	Standard Broadcast-Police Calls
B	1720-5400	Amateur-Police Calls-Aviation
C	5400-18000	Amateur-S-W Broadcast-Aviation

Intermediate Frequency—460 kilocycles.

Power Output—1.75 watts (undistorted); 3.5 watts (maximum).

Loudspeaker—Electrodynamic (voice-coil impedance 4 ohms).

Tubes—2 RCA-6D6 (R-F and I-F Amplifiers), 1 RCA-6A7 (Oscillator and 1st Detector), 1 RCA-6D6 (Beat Oscillator), 1 RCA-6B7 (2nd Detector,

A.V.C. and A-F Amplifier), 1 RCA-42 (Output), and 1 RCA-80 (Rectifier). See diagram on label inside cabinet lid for locations of tubes, tube shields and grid leads.

Power-Supply Ratings—See rating symbol on chassis.

Symbol	Voltage	Frequency (cycles)
A	105-125	50-60
B	105-125	25-60
C	100-130/195-250	50-60

As shipped from factory, instruments rated "C" are connected for 225-250 volts unless prominently specified otherwise on chassis. Any of these, however, can be converted for operation at 100-117, 117-130 or 195-225 volts when required. (See A-C Line Voltages in Part II.)

Power Consumption—85 watts.

Antenna Requirements

For amateur and other short-wave reception, the importance of a good antenna installation cannot be exaggerated. Signals of this class are apt to be weak, seldom much above the noise level under average atmospheric conditions. Irrespective of the degree of perfection of the receiver, therefore, an efficient antenna is prerequisite to reliable reception.

Because of its *noise-reducing* and pronounced directional properties, the *doublet-type* antenna has enjoyed considerable popularity. A single doublet, however, is restricted in frequency coverage to the same extent as the conventional single-wire antenna, a given length being very satisfactory at certain fre-

quencies but relatively poor at others. For best results, the use of a special antenna system or of multiple antennas of the single-wire or doublet-type is essential.

The new *double-doublet* antenna system offers a practical solution to this problem. It consists essentially of *two* doublet antennas having different lengths and therefore different resonance characteristics, interconnected so that one will compensate for the weak points of the other throughout the intervening frequency range. An excellent antenna of this type, intended particularly for radio amateurs and other

experimenters, is now available in the form of a convenient accessory kit known as No. 9550.

Except for omission of the antenna wire and a few other readily-procurable items, this kit is identical to the No. 9500-A—a complete kit recommended for use with the new “all-wave” receivers for home entertainment. In the latter, the doublet lengths are

correct to embrace the short-wave broadcasting bands at 16, 19, 25, 31 and 49 meters. Different lengths of course should be used to insure best results over any other frequency range. With each No. 9550 kit are furnished concise instructions for computing doublet lengths and for altering the system to suit individual requirements.

Operation

Controls

All controls except the beat oscillator frequency adjustment are located upon the front panel and identified insofar as necessary by adjacent markings.

Power Switch and Sensitivity Control—The POWER switch is combined with a SENSITIVITY control and operates at the counter-clockwise end of rotation. When the knob is turned clockwise from latter extremity, the switch closes initially to apply power to receiver and continued rotation increases the sensitivity of receiver gradually to a maximum. Sensitivity is controlled by variation of the grid-bias voltage applied to the r-f and i-f amplifiers. In operation, this control may be employed to provide “silent tuning” between station settings. It is particularly advantageous, however, as an auxiliary volume control when the automatic volume control action of the receiver is removed.

Tone Control—Next in order to the right is a TONE control for attenuation of the higher frequencies, *full-range* reproduction being obtained with the knob turned fully clockwise. Under adverse weather conditions, static interference generally will be reduced to an appreciable extent by restricting the audio-response range. The control circuit consists of a variable resistor in series with a fixed capacitor and is connected across the primary of the output transformer.

Beat Oscillator Switch—The C. W. OSC. switch, located immediately to the right of the tone control, serves to interrupt plate and screen grid supply voltages to the beat-frequency oscillator stage. Thus, that stage can be rendered inoperative at any time, but, since the filament remains heated continuously, is ready for instantaneous operation.

Beat Oscillator Frequency Control—To provide manual control of the output frequency over a limited range on each side of the “zero-beat” position, a midget variable air capacitor is connected across the main tuning capacitor for the beat oscillator stage. Such adjustment is made inside the case upon lifting the lid, the small capacitor being located inside a shield at the rear left-hand corner of the chassis and operated by means of a horizontal rod pivoted from the top of that shield.

Tuning Control—The knob directly beneath the dial is the main tuning control. This knob when

set inward affords a drive ratio of 10:1 for rapid adjustment and, when pulled out, engages a secondary drive with a ratio of 50:1 for precise tuning—a valuable feature for short-wave work.

Range Switch—The following knob to the right is a RANGE switch for selecting any of the three bands whose frequency limits are tabulated under “Electrical Specifications.” A visual band indicator operates in conjunction with this knob, the band letters corresponding to the various switch positions appearing in sequence through a small opening in the lower half of the dial.

Volume Control—The VOLUME control is connected in the audio-frequency circuit and increases the output level with clockwise rotation.

Automatic Volume Control Switch—On the extreme right-hand end of the front panel is the A.V.C. control—a switch for eliminating automatic volume control action to obtain best reception of slow-speed code transmission.

Stand-by Switch—The toggle switch located on the front panel is connected in the plate circuit of the rectifier stage. When thrown to the left, all plate and screen grid voltages are removed, but the filament supply is unaffected, leaving the receiver “warmed-up” so that operation can be resumed instantaneously. Amateurs will find this switch highly advantageous for silencing the receiver during “sending” periods.

Phone Jack—The phone jack on the front panel at the extreme left-hand end permits quick substitution of headphones for reception of extremely weak signals. When a phone plug is inserted in this jack, it simultaneously short-circuits the voice coil of the electrodynamic loudspeaker and connects the phones through a small capacitor across the plate circuit of the power output stage. Since the loudspeaker field is employed as a filter for the rectifier stage, that unit still forms an active part of the circuit when using headphones.

Dial

The dial of this instrument incorporates a mechanical band-spread system particularly suited to amateur or other work where a fine degree of resetability is required. In addition to the three main scales calibrated directly in frequency (kilocycles or megacycles), two arbitrary scales are available for

precision logging. These are known as the *vernier* and *vernier index* scales, the former being fully circular at the outside of the dial and the latter semi-circular at the center of the dial.

It will be observed that the *vernier* scale is graduated from "0" to "100" and traversed by the long single-ended pointer. On the other hand, the *vernier index* scale is graduated from "0" to "9" and traversed by the short double-ended pointer used for the main frequency scales. The longer pointer makes one complete revolution for each unit of travel of the shorter pointer on the *vernier index* scale. Thus, any station may be logged accurately with three digits; for example, if the *vernier index* reading is between "3" and "4" and the *vernier* reading is "72," then the log number is "372." The index number is always the lower of the two numbers between which the pointer is located.

In logging stations by this method, the band *letter* also must be named. For the above example, therefore, the full log number would be "A-372," "B-372," or "C-372," depending upon the setting of the range switch. As mentioned under "Controls," the band letter is visible through a small opening near the bottom of the dial.

In circuits where the tuning capacitor covers a relatively wide frequency range, the advantage of mechanical band spreading over the well-known electrical method lies in the greater uniformity of separation obtainable throughout that range and in the convenience of single-control tuning. With electrical band spreading, it is general practice to connect small variable capacitors in parallel with the main tuning (tank) capacitors. If such a system were employed, the various "amateur" channels could not be spread as uniformly since for a given frequency change, the travel of the band-spreading capacitors would be far less at the high-frequency end of the scale than at the low-frequency end; in other words, band-spread action would be very effective for the "amateur" channels at 40 meters (band C) and 160 meters (band B) but relatively poor for the two remaining channels at 20 meters (band C) and 80 meters (band B). In addition to this fundamental defect, there would be required at least one additional dial and the probability of error in reading or re-setting would be greatly increased. The direct-reading frequency scale of this receiver obviously is possible only with a single tuning control and should be found very convenient.

Beat Oscillator

The beat-frequency oscillator embodied in this receiver is of the electron-coupled type, known to afford excellent frequency stability. Its primary purpose, of course, is to enable the reception of c-w (continuous-wave) telegraph signals, but it also may be used to advantage in locating regular broadcast or other modulated forms of transmission by the "birdie" method. Although the latter practice usually will be unnecessary because of the high sensitivity of this receiver, it may be found expedient in cases where the

signal strength is very low or the carrier is not modulated continuously.

For c-w reception, it is customary to adjust the oscillator frequency to a value one or two kilocycles above or below the intermediate frequency of the receiver. Thus, all carriers to which the receiver can be tuned will be heard at *exact* resonance as notes of the same pitch since the beat or separation frequency will be constant throughout the entire tuning range. The pitch, of course, may be varied at will by changing the output frequency of the oscillator, either to satisfy personal preference or to eliminate interfering signals. Best intelligibility and greater apparent volume due to the inherent sensitivity characteristic of the human ear will result using a moderately low-pitch or beat frequency in the order of 500 to 1000 cycles, but *audio-image* interference will decrease with ascending pitch.

Audio-image interference is an effect entirely distinct from that commonly referred to in superheterodynes by the term "image-frequency response." By the latter is meant interference set up by an incoming carrier on the same side of the desired carrier as the *radio-frequency* oscillator but removed by *exactly* twice the receiver intermediate frequency. Such interference in this receiver is rendered negligible through the use of a pre-selector or radio-frequency amplifier stage.

When using the beat oscillator, interference of the same pitch as the desired signal can be produced by any continuous-wave signal which upon passing through the receiver is converted to an intermediate frequency on the same side of the receiver intermediate frequency as the beat oscillator but removed by *exactly* twice the separation of the beat oscillator. In this case, the interfering signal would be a *true* audio image. If one merely visualizes the sharp selectivity curve of the superheterodyne, he will observe at once that the attenuation offered by the tuned circuits of the receiver to such *image* responses will increase very rapidly as the oscillator separation is widened.

It should be appreciated in relation to the preceding paragraph that interference signals can be encountered not only at the *audio-image* frequency but at any frequency above or below the beat oscillator frequency at a separation within the audio range. Such beat notes ordinarily will be distinguishable from that of the desired signal because of the dissimilarity of pitch. In cases where both sound almost alike, confusion between the desired and undesired signals can practically always be eliminated by shifting the setting of the beat oscillator.

If a beat note of approximately the same pitch as the desired signal is heard, the interfering signal must be either near the frequency of resonance or near the *audio-image* frequency. For the first condition, best discrimination will be obtained using a fairly low pitch frequency on the opposite side of zero beat from the interfering frequency. Use of a relatively low pitch is recommended since for a given small frequency separation, say 100 cycles, two notes will be

much more discernible in the region of 500 cycles than at 1500 cycles. When the interfering signal is at or near the *audio-image* frequency, however, two alternatives are possible. The oscillator frequency either can be adjusted to zero beat with the frequency of interference or swung through zero beat with the desired signal to some value on the opposite side of i-f resonance.

As an example to illustrate the latter alternatives, suppose that with the receiver tuned to a station the beat oscillator is adjusted to one kilocycle *above* the intermediate frequency and that an interfering signal is present at 1900 cycles above i-f resonance (100 cycles below the *audio-image* frequency). Thus, the desired signal will produce a one kilocycle note and the interfering signal a note of 900 cycles, these tones being sufficiently close that the former probably would not be readily discernible. By increasing the oscillator frequency 900 cycles, however, the desired signal would be heard as a 1900 cycle note and the undesired signal heterodyned to zero frequency. On the other hand, the oscillator frequency could be changed to a point on the opposite side of i-f resonance so that the desired signal would again be heard as a one kilocycle note. The interfering signal then would produce a note of 2900 cycles and so should cause no confusion.

Tuning

The r-f amplifier, oscillator and first detector circuits of this superheterodyne are tuned by a three-gang variable capacitor and thus controlled from a single knob. Tuning is even simpler than with the ordinary broadcast receiver because of the dual-ratio *vernier* drive system used in conjunction with the gang capacitor as mentioned under "Controls." For regular broadcasting and "amateur" phone stations, proceed as follows:

1. Turn Power Switch "on" and advance Sensitivity Control fully clockwise for *maximum* sensitivity.
2. Select position of Range Switch at which the band letter visible through small opening in dial corresponds to that frequency scale which includes the desired station or channel.
3. Set Standby and A.V.C. Switches "on" and Beat Oscillator Switch "off."
4. Advance Volume Control (clockwise) until background noise is heard.
5. Push tuning knob "in" and rotate short pointer to approximate setting of desired station, then pull knob "out" and adjust to the exact center of carrier.
6. Decrease volume as necessary and adjust Tone Control for preferred quality of reproduction.

If several moderately strong stations are available, silent tuning *between station settings* may be obtained by turning Sensitivity Control counter-clockwise until background noise (at any point on dial where no signal is heard) *just* disappears. Obviously,

weak or distant stations *below* the noise level will not be received after this adjustment.

As noted heretofore, the beat oscillator may be used to advantage in locating weak, modulated signals. It should be tuned for this purpose exactly to the intermediate frequency of the receiver so that an audio-frequency note of ascending pitch will be obtained on each side of every incoming carrier. To adjust the beat oscillator in this manner, simply tune the receiver accurately to any carrier of suitable strength, then turn the Beat Oscillator Switch "on" and swing the small horizontal rod (inside the case) in either direction until "zero beat" is obtained. It follows then, of course, that any other carrier will be tuned to exact resonance when the gang or tuning capacitor is adjusted for "zero beat" and that weak signals will be heard almost as well as those of greater strength because of the heterodyne "whistle" produced while passing through resonance.

For c-w (code) reception, the tuning procedure is the same as for modulated signals except that the beat oscillator performs a definite rather than incidental function. It is set not *at* the intermediate frequency, but slightly *above* or *below* so as to provide an audio-frequency beat note when the receiver is tuned to resonance with any carrier. The gang capacitor, therefore, should be adjusted to the center of the carrier by listening to the "swish" or "key clicks" before turning "on" the Beat Oscillator Switch. Always adjust the pitch with the horizontal rod—never by means of the tuning control knob.

Short-Wave Reception

The short-wave broadcast facilities of this instrument may be used to greatest advantage by keeping in mind the usual variations in behavior with frequency of transmission and the time standards observed at different longitudes. In general, such reception is most satisfactory at the highest frequencies when the major portion of the transmission path is in daylight, and the lowest frequencies when the reverse is true.

Unreliable service from distant short-wave stations ordinarily is attributable either to fading or to the so-called "skip effect" encountered when the sky wave is reflected back to earth at a point beyond the radius of the local or ground wave. The latter component travels a relatively short and uniform distance (perhaps 35 miles at 19 meters and 75 miles at 49 meters), whereas the return point of the sky wave is extremely variable, increasing in distance from the transmitter from day to night and from summer to winter as well as with frequency. Obviously, reception in the intervening of "skip-distance" region will be either impossible or very erratic, such conditions existing usually over a range of from 25 to 400 miles at 49 meters and from 400 miles to infinity at 19 meters.

The program schedules listed on the accompanying chart are given with respect to both Eastern Standard and Greenwich Mean times, either of which is readily convertible to time standards observed at other longitudes.

Part II

SERVICE NOTES

Circuit Description

Before attempting to align or otherwise adjust this receiver, it is advisable to form a general knowledge of the circuit arrangement. A schematic diagram of the complete circuit is shown in Figure 1 (frontispiece). Figure 2 illustrates the arrangement of wiring which interconnects the radio chassis, loud-speaker and front-panel controls while the wiring layout of the radio chassis independently is detailed in Figure 3.

A signal upon entering the receiver passes through a shielded lead to the antenna coupling transformer, the secondary of which is tuned by one section of the three-gang variable capacitor, and is thence impressed upon the grid of the r-f amplifier—a stage of pre-selection used primarily for reducing image-frequency interference to a negligible value. The output of this stage is transformer coupled to the grid circuit of the first detector which also is tuned to the signal frequency by the second unit of the gang capacitor.

As in all superheterodynes, the first detector is actually a mixer stage, combining the incoming r-f carrier with an unmodulated sinusoidal voltage pro-

duced by a local oscillator. The functions of the first detector and oscillator are performed by a single tube.

It should be noted at this point that the three tuning ranges are obtained through a coil-selector system in conjunction with the one three-gang variable capacitor. Three sets of coils, each set consisting of three coils, are employed and with each shift of the range switch, a different and complete coil set is substituted. In addition to selecting the desired coil set, other contacts are provided on the range switch to short-circuit the coil set for band A when operating in band B and the coil set for band B together with the oscillator coil for band A when operating in band C. This practice prevents the occurrence of "dead spots" in bands B and C because of absorption effects in coil sets A and B which (when untuned) have natural periods within the range of the next higher-frequency band.

The beat frequency set up in the first detector carries the same modulation as the original r-f signal and is commonly termed the *intermediate* frequency. Since this intermediate frequency is constant for all r-f carriers, the next (i-f amplifier) stage utilizes fixed tuning. Its grid circuit is coupled to the first detector

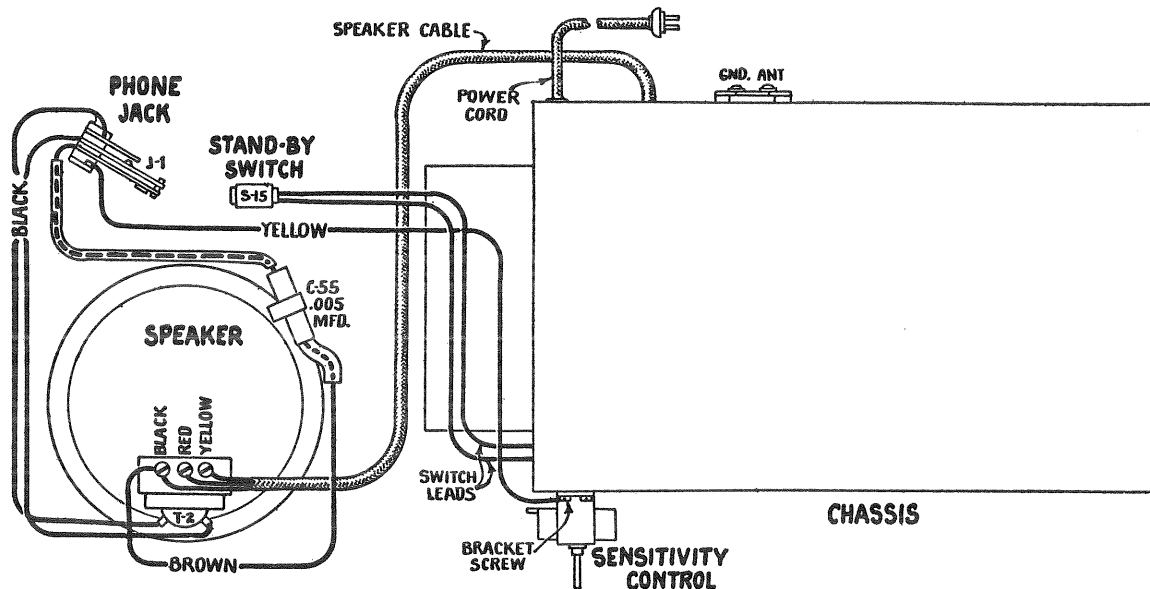

Figure 2—Assembly Wiring Diagram

duced by a local oscillator. The oscillator plate circuit, being tuned by the third section of the gang capacitor, maintains a constant frequency difference from the transmitted signal throughout the entire tuning range. Thus, a difference or *beat* frequency is developed when any signal is received which is the same at each position of exact resonance. In this

through a transformer, both windings of which are tuned to the intermediate frequency (460 kilocycles) by means of independent adjustable capacitors. A similarly-tuned transformer is used to couple the output of this amplifier to the second detector, making a total of four capacitors for adjustment during alignment.

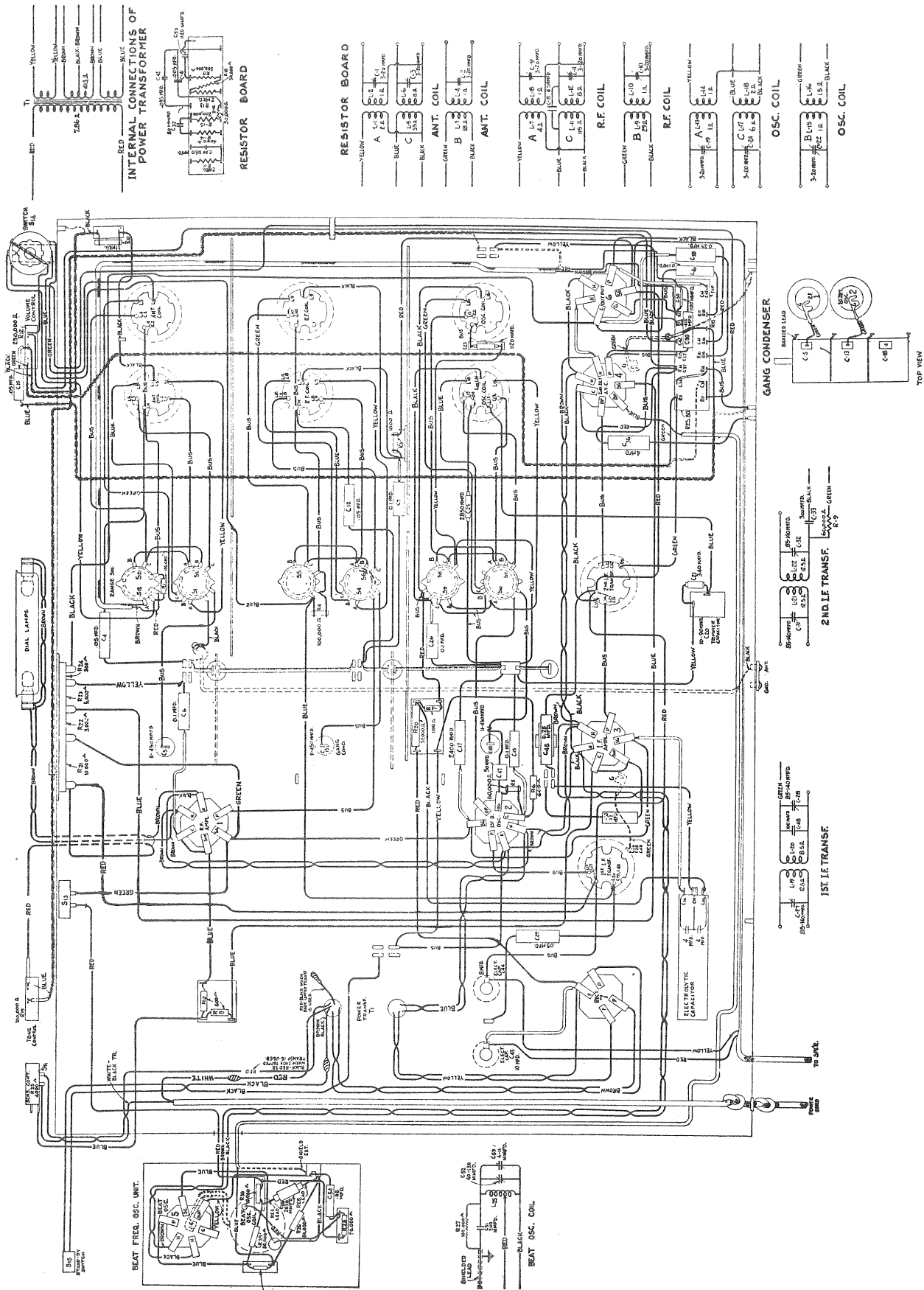

Figure 3—Chassis Wiring Diagram

The incoming (i-f) amplifier signal and the frequency generated by the beat oscillator for c-w reception are applied independently to the diode plate elements contained in the second detector tube and are combined therein to produce an audio-frequency note which can be heard readily in the loudspeaker or phones. As mentioned in the foregoing section, the variable capacitor operated by the horizontal rod inside the case is actually a vernier control which permits adjustment of the oscillator output frequency over a very limited range on either side of the signal intermediate frequency. It is effectively connected in parallel with the main tuning capacitor for the oscillator stage (likewise a variable air-dielectric unit accessible for adjustment by means of a screwdriver through an opening in bottom of case). Both capacitors together with the oscillator tuning coil are contained inside a single shield.

In addition to serving as a detector for both c-w and modulated signals, the second detector stage also performs functions of audio-frequency amplification and automatic volume control. The volume control resistor is connected as a series element in the diode detector circuit and so has developed across it a negative d-c potential of an amplitude that varies directly in accordance with the strength of the original r-f carrier. By returning this potential or portions thereof to the grids of the r-f amplifier, first

detector and i-f amplifier, these tubes are biased in varying degree to compensate for fluctuations in field strength (fading) and for extreme changes of r-f input when tuning. The switch in this circuit permits elimination of the automatic volume control feature by removing all variable bias from the aforementioned tubes.

The audio-frequency component of the detected signal is fed through the arm of the volume control to the control grid of the tube for amplification. Resistance coupling is used between the pentode plate and the power output stage which also is connected as a pentode for high-power amplification. The plate circuit of the output stage is matched to the cone coil of the electrodynamic loudspeaker through a step-down (output) transformer.

A tone control circuit consisting of a variable resistor and a fixed capacitor in series is connected across the primary of the output transformer. The sensitivity control is a variable resistor common to the cathode circuits of the r-f and i-f amplifiers for alteration of self-bias produced by the combined plate currents for those tubes.

All power voltages are obtained from a full-wave rectifier and filter system connected to the a-c line. The loudspeaker field coil is excited from this system and serves therein as a filter reactor.

A-C Line Voltages

As noted under Electrical Specifications in Part I, this receiver is manufactured in three a-c line ratings designated as A, B and C, respectively. The first two models (A and B) cover a single-voltage range (105 to 125 volts), whereas the third or "C" model is operable in either of four ranges (100 to 117, 117 to 130, 195 to 225 and 225 to 250), three taps being provided on the primary of the power transformer. Internal connections of the transformer are shown in Figure 4. All taps are brought out to a terminal board on the top of the transformer and may be interchanged without removing the chassis from its case.

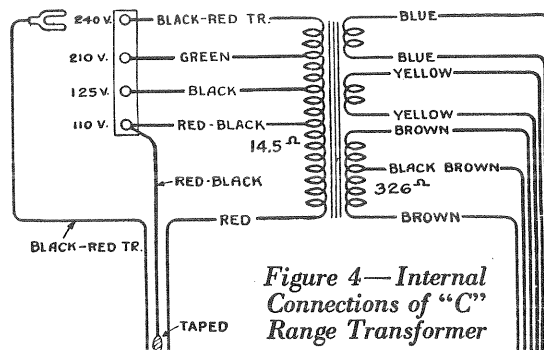

Figure 4—Internal Connections of "C" Range Transformer

Tube Voltages

The following voltages are normal at the tube sockets when the receiver is operating at 115 volts a-c line, with no incoming r-f signal, with the volume and sensitivity controls at "maximum" (both turned fully clockwise), and with the automatic volume con-

trol switch turned to the "on" position. Such voltages, of course, were measured with high-resistance meters. If low-resistance meters are used in checking, therefore, allowances must be made for meter-current drain. See Figure 5.

Radiotron Type Number	Cathode to Ground (Volts)	Screen Grid to Ground (Volts)	Plate to Ground (Volts)	Plate Current (M. A.)	Heater Volts
RCA-6D6 (R-F Amplifier)	6.0	105	265	9.0	6.3
RCA-6A7	6.0	105	265	3.5	6.3
			220	4.5	
RCA-6D6 (I-F Amplifier)	6.0	105	265	9.0	6.3
RCA-6D6 (Beat Oscillator)	—	50*	40*	—	6.3
RCA-6B7 (2nd Detector)	3.0	50	90*	0.7	6.3
RCA-42 (Output)	16.5	265	245	30.0	6.3
RCA-80 (Rectifier)	—	—	690 (r-m-s) Plate to Plate	70.0 Total	5.0

* Difficult to measure—Calculated from 265 Volts (+B).

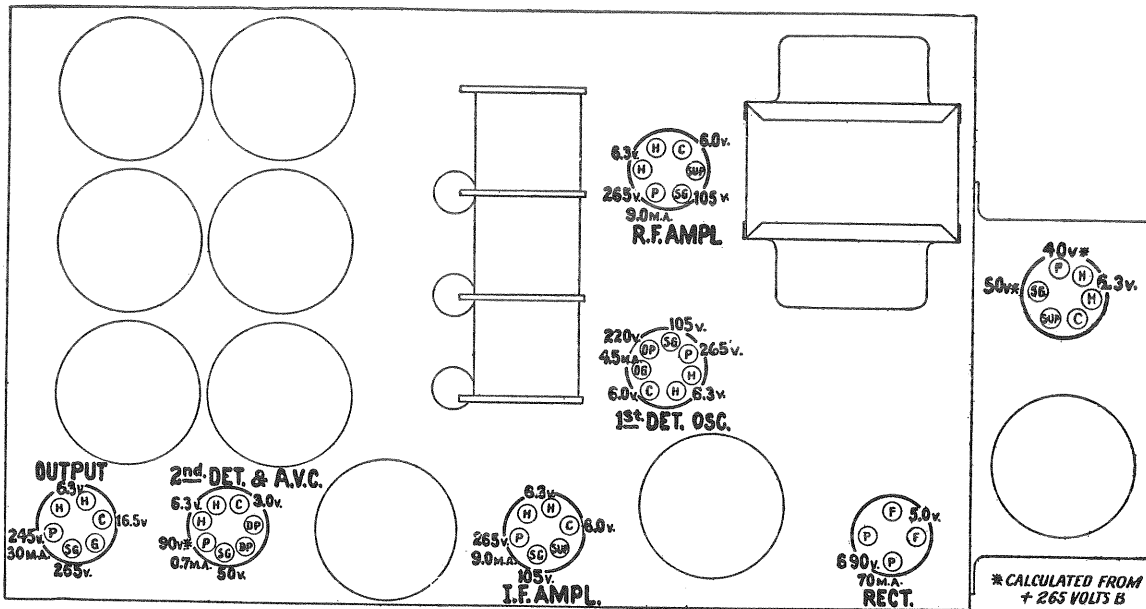

Figure 5—Tube Voltages

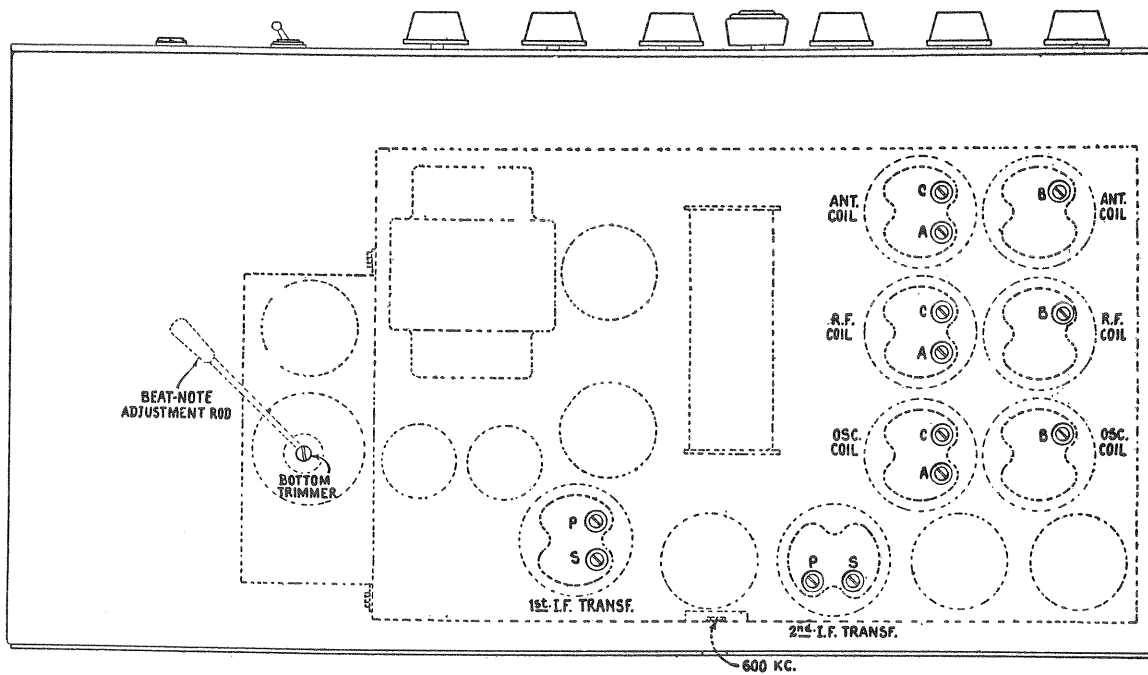

Figure 6—Locations of Trimmers (viewing bottom of case)

Alignment Procedure

This receiver, of course, was aligned at the factory, but should be checked regularly (preferably once every six months) to insure best possible results. Adjustments when necessary can be performed easily since all trimmer capacitors are accessible through openings in the external case as shown in Figure 6. If desired, however, the chassis can be withdrawn upon removal of the front panel and four mounting screws.

Equipment

Good equipment is prerequisite to satisfactory alignment. A modulated r-f oscillator having an adequate frequency range such as No. 9595, an output meter or simply an output indicator such as No. 4317, and a non-metallic screwdriver such as No. 4160 are three very necessary items. The process can be greatly facilitated through use of tuning wand No. 6679. The parts to which these numbers apply were designed by the manufacturer of this receiver for use by its authorized servicemen. Such parts, however, can be purchased by radio amateurs or engineers through the regular commercial channels.

I-F Alignment

Both the primary and the secondary circuits of the two coupling transformers for the i-f stage are tuned. Thus, four trimmers may require adjustment to the nominal intermediate frequency—460 kilocycles. To effect these adjustments, refer to Figure 6 and proceed as follows:

1. Connect a modulated oscillator so that its output is impressed between the grid of the first detector and ground.

2. Connect an output indicator across the voice coil of the loudspeaker or an output meter across the secondary of the output transformer with the loudspeaker voice coil open-circuited.

3. Remove the antenna lead-in connection from the rear (ANT-GND) terminal board. Apply power to receiver, turn volume and sensitivity controls fully clockwise (for maximum output) and set tuning control to any point in band A where no signal is received.

4. Place the oscillator in operation at 460 kilocycles and adjust its output control to a position just sufficient to actuate the output meter or indicator.

5. Adjust each of the four trimmer capacitors in turn for maximum output, reducing the input from the oscillator in order to maintain a suitable reading at all times. It will be advisable to go over these adjustments again to make certain that each circuit is exactly peaked rather than merely approximately correct. When an i-f alignment has been made, always follow with the r-f adjustments, as an interlocking effect is usually incurred.

R-F Alignment

The r-f amplifier, oscillator and first detector stages include a total of four trimmers in band A and totals of three trimmers each in bands B and C. These bands should be aligned individually and in alphabetical sequence. Care must be used to avoid disturbing the adjustments of trimmers not involved in the band under test. Nominal line-up frequencies for band A are 600 and 1720 kilocycles, while bands B and C are aligned at 5160 and 18000 kilocycles, respectively. For these adjustments, refer to Figure 6 and proceed as follows:

1. Check setting of dial pointer and adjust if necessary. With tuning capacitor plates fully meshed, one end of the pointer should point exactly toward

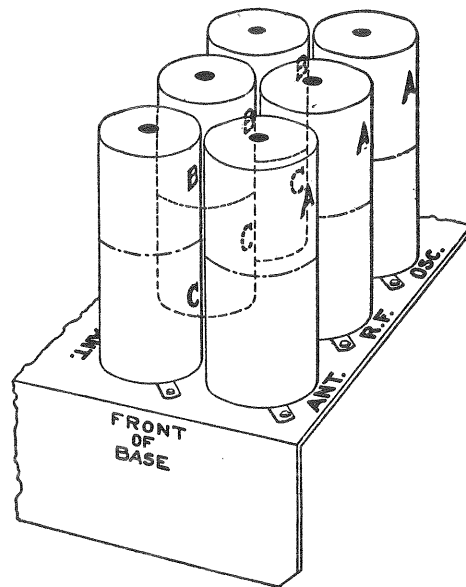

Figure 7—Locations of R-F Coils

the horizontal line at the low-frequency end of band A while the other end should point to within 1/64 inch of the horizontal line at the high-frequency end of that band.

2. Connect a modulated oscillator to the antenna (ANT) and ground (GND) terminals of the receiver.

3. Connect an output indicator across the voice coil of the loudspeaker or an output meter across the secondary of the output transformer with the loudspeaker voice coil open-circuited.

4. Apply power to receiver and turn volume and sensitivity controls fully clockwise (for maximum output).

5. Set range switch at "A":

- (a) Adjust oscillator series capacitor (accessible from rear of case) to approximately the center of its range.
- (b) Place test oscillator in operation at 1720 kilocycles, set dial pointer at 1720 kilocycles and adjust the three trimmers designated by the letter "A" (Figure 6) for maximum output.

- (c) Shift test oscillator frequency to 600 kilocycles and tune receiver to this signal irrespective of the actual dial reading, then adjust the oscillator series trimmer (accessible through opening in rear of case) for maximum output while rocking the tuning capacitor.
 - (d) Re-adjust at 1720 kilocycles as described in (b).
6. Set range switch at "B":
- (a) Tighten the r-f amplifier and first detector trimmers to afford approximately three-quarters of their maximum capacitance—that is, screwed inward three-quarters of the total travel.
 - (b) Shift test oscillator frequency to 5160 kilocycles, set dial pointer at 5160 kilocycles and adjust oscillator trimmer for maximum output. Set the trimmer at the first peak obtained while increasing the capacitance from "minimum" position.
 - (c) Check for the image signal at approximately 4240 kilocycles on dial (increasing the test oscillator output if necessary) in order to make certain that the oscillator trimmer is adjusted correctly in accordance with paragraph (b).
 - (d) Reset dial to 5160 kilocycles and reduce the capacitance of the first detector trimmer until signal disappears. (At this setting, the detector is tuned to the same frequency as the oscillator and the RCA-6A7 tube is blocked.) Now, increase the trimmer capacitance while rocking the tuning capacitor until maximum output is attained.
 - (e) Adjust the r-f amplifier trimmer for maximum output. It is not necessary to rock the tuning capacitor during this adjustment.

7. Set range switch at "C":

- (a) Follow the same procedure as for band B (6) except use a test frequency of 18000 kilocycles and check for the image signal at 17,080 kilocycles.

During these adjustments, always leave the *sensitivity* and *volume* controls of the receiver at "maximum." To maintain a suitable output, reduce the test-oscillator input as necessary. In the high-frequency bands, it may be found necessary to disconnect the test oscillator and place it at an appreciable distance from the receiver.

Tuning Wand—This tool permits checking the accuracy of r-f alignment without disturbing any of the trimmer adjustment screws. It consists of a bakelite rod with a brass cylinder at one end and iron laminations at the other end. An opening is provided in the top surface of each shield in the r-f assembly (see Figure 7) for inserting the wand. Obviously, the inductance of any coil will be lowered when the brass end is inserted and will be raised upon insertion of the iron end. The trimmer setting is correct when the output at alignment frequencies is decreased alike by each end of the wand. If either end causes an increase in output, it is evident that the associated trimmer requires adjustment.

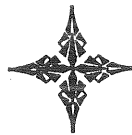

REPLACEMENT PARTS

Stock No.	DESCRIPTION	List Price	Stock No.	DESCRIPTION	List Price
RECEIVER ASSEMBLIES					
4427	Bracket—Volume control or tone control mounting bracket.....	\$0.18	3997	Resistor—4000 ohms—Carbon type— $\frac{1}{4}$ watt (R14)—Package of 5.....	\$1.00
4244	Cap—Contact cap—Package of 5.....	.20	3114	Resistor—50,000 ohms—Carbon type— $\frac{1}{4}$ watt (R16, R18)—Package of 5.....	1.00
3861	Capacitor—Adjustable trimmer capacitor (C20).....	.78	3602	Resistor—60,000 ohms—Carbon type— $\frac{1}{4}$ watt (R5)—Package of 5.....	1.00
4442	Capacitor—50 mmfd. (C47).....	.22	3118	Resistor—100,000 ohms—Carbon type— $\frac{1}{4}$ watt (R1, R4)—Package of 5.....	1.00
4662	Capacitor—80 mmfd. (C37).....	.24	3116	Resistor—200,000 ohms—Carbon type— $\frac{1}{4}$ watt (R15)—Package of 5.....	1.00
4811	Capacitor—340 mmfd. (C21).....	.25	6186	Resistor—500,000 ohms—Carbon type— $\frac{1}{4}$ watt (R17)—Package of 5.....	1.00
4412	Capacitor—1120 mmfd. (C23).....	.25	4783	Resistor—1,100,000 ohms—Carbon type— $\frac{1}{4}$ watt (R10)—Package of 5.....	1.00
4515	Capacitor—1160 mmfd. (C34).....	.22	6242	Resistor—2 megohms—Carbon type— $\frac{1}{4}$ watt (R11, R13)—Package of 5.....	1.00
4634	Capacitor—1120 mmfd. (C50).....	.35	2240	Resistor—30,000 ohms—Carbon type—1 watt (R20).....	.22
4523	Capacitor—2400 mmfd. (C17).....	.26	4721	Resistor—Tapped resistor, one 10,000 ohms, two 5000 ohms, and one 500 ohms section (R21, R22, R23, R24).....	.88
4524	Capacitor—2850 mmfd. (C25).....	.35	4521	Shield—I. F. transformer shield.....	.42
4792	Capacitor—.015 mfd. (C39).....	.22	4742	Shield—Antenna R. F. or oscillator coil shield.....	.40
4518	Capacitor—.05 mfd. (C35).....	.52	3942	Shield—First detector or output Radiotron shield.....	.18
4836	Capacitor—.05 mfd. (C4, C12, C29).....	.30	7487	Shield—I. F. amplifier Radiotron shield.....	.25
4841	Capacitor—.1 mfd. (C6, C15, C30, C40).....	.22	4705	Shield—R. F. amplifier Radiotron shield.....	.30
4885	Capacitor—.1 mfd. (C7, C26).....	.28	3782	Shield—Second detector Radiotron shield.....	.26
3597	Capacitor—.25 mfd. (C38, C45).....	.40	3529	Socket—Dial lamp socket.....	.32
4525	Capacitor—4.0 mfd. (C36).....	.70	4784	Socket—4-contact Radiotron socket.....	.15
4428	Capacitor—8 mfd. (C44).....	1.05	4786	Socket—6-contact output Radiotron socket.....	.15
7790	Capacitor—10 mfd. (C43).....	1.05	4785	Socket—6-contact Radiotron socket.....	.15
4692	Capacitor pack—Comprising one 0.035 mfd. and one 0.005 mfd. capacitors (C41, C42).....	.30	4787	Socket—7-contact Radiotron socket.....	.15
7589	Capacitor pack—Comprising two 4. mfd. capacitors (C16, C46).....	1.64	4379	Strip—Antenna terminal engraved "ANT-GND".....	.20
4358	Clamp—Electrolytic capacitor mounting clamp.....	.15	4684	Switch—Oscillator switch (S13).....	.45
4808	Coil—Antenna coil "Band B" (L3, L4, C2).....	1.92	4728	Switch—Range switch (S1, S2, S3, S4, S5, S6, S7, S8, S9, S10, S12).....	4.32
7803	Coil—Antenna coil "Band A-C" (L1, L2, L5, L6, C1, C3).....	1.32	4810	Tone control (R19).....	1.30
4815	Coil—Detector coil "Band B" (L9, L10, C10).....	1.30	4431	Transformer—First intermediate frequency transformer (L19, L20, C27, C28, C48).....	2.28
7805	Coil—Detector coil "Band A-C" (L7, L8, L11, L12, C8, C9, C11).....	2.15	4433	Transformer—Second intermediate frequency transformer (L21, L22, C31, C32, C33, R9).....	2.15
7807	Coil—Oscillator coil "Band A-C" (L13, L14, L17, L18, C19, C24).....	1.62	9511	Transformer—Power transformer—105-125 volts, 50-60 cycles (T1).....	4.78
4807	Coil—Oscillator coil "Band B" (L15, L16, C22).....	1.85	9512	Transformer—Power transformer—105-125 volts, 25-40 cycles.....	6.58
7801	Condenser—3-gang variable tuning condenser (C5, C13, C18).....	4.42	9513	Transformer—Power transformer—105-250 volts—40-60 cycles.....	4.85
4340	Lamp—Dial lamp—Package of 5.....	.60	4809	Volume control (R12).....	1.45
3218	Resistor—600 ohms—Carbon type— $\frac{1}{4}$ watt (R2, R6, R8)—Package of 5.....	1.00			
4834	Resistor—1100 ohms—Carbon type— $\frac{1}{4}$ watt (R3, R7)—Package of 5.....	1.00			

REPLACEMENT PARTS (Continued)

Stock No.	DESCRIPTION	List Price	Stock No.	DESCRIPTION	List Price
DRIVE ASSEMBLIES					
4362	Arm—Band indicator operating arm.....	\$0.28	3381	Resistor—10,000 ohms—Carbon type— $\frac{1}{4}$ watt (R30)—Package of 5.....	\$1.00
10194	Ball—Steel ball for variable condenser drive assembly—Package of 20.....	.25	3114	Resistor—50,000 ohms—Carbon type— $\frac{1}{4}$ watt (R26, R28, R29)—Package of 5.....	1.00
4422	Clutch—Tuning condenser drive clutch assembly—Comprising drive shaft, balls, ring, spring and washers assembled.....	.88	6955	Shield—Oscillator Radiotron shield.....	.25
4724	Dial—Station selector dial.....	.40	7485	Socket—6-contact Radiotron socket.....	.40
7799	Drive—Variable tuning condenser drive assembly complete.....	2.45	REPRODUCER ASSEMBLY		
4364	Gear—Spring gear assembly complete with hub pinion, gear cover and spring.....	.96	4448	Board—Terminal board assembly.....	.25
4361	Indicator—Band indicator—Celluloid.....	.12	9531	Coil—Field coil, magnet and cone support (L24).....	2.75
4520	Pointer—Station selector main pointer—Large.....	.18	9492	Cone—Reproducer cone (L23)—Package of 5.....	3.70
4725	Pointer—Station selector vernier pointer—Small.....	.22	9514	Reproducer—Complete.....	6.00
3993	Screw—No. 6-32- $\frac{5}{32}$ " square head set screw for variable condenser drive assembly—Package of 10.....	.25	4505	Transformer—Output transformer (T2).....	1.55
4377	Spring—Band indicator and arm tension spring—Package of 5.....	.25	4447	Shield—Terminal board shield.....	.18
4360	Stem—Pointer stem assembly.....	.35	MISCELLANEOUS ASSEMBLY		
4378	Stud—Band indicator operating arm stud—Package of 5.....	.25	4757	Bezel—Station selector dial (escutcheon) bezel.....	.82
OSCILLATOR ASSEMBLIES					
2747	Cap—Contact cap—Package of 5.....	.50	6614	Glass—Station selector dial glass.....	.30
3640	Capacitor—.05 mfd. (C54).....	.25	11314	Grille—Grille cloth and screen assembly for speaker.....	.18
3794	Capacitor—100 mmfd. (C57).....	.30	4823	Knob—Station selector knob—Package of 5.....	.75
4524	Capacitor—2850 mmfd. (C56).....	.35	4132	Knob—Volume control, tone control, sensitivity control, oscillator switch, range switch or AVC switch knob—Package of 5.....	.55
5029	Coil—Beat coil—Oscillator assembly—Complete (R27, C51, C52, C53, L25).....	7.28	6615	Ring—Dial glass retaining ring—Package of 5.....	.34
8077	Handle—Beat oscillator adjustment handle—Complete with knob.....	.50	3943	Screen—Translucent screen for dial light—Package of 2.....	.18
			4613	Screw—Number 8-32- $\frac{1}{16}$ " headless set screw for knobs—Package of 10.....	.25
			4726	Rheostat—Sensitivity control rheostat (R25, S11).....	1.42
			4756	Jack—Phone jack (J1).....	1.44
			4758	Switch—Standby switch (S15).....	.95
			4727	Switch—AVC control switch (S14).....	1.44