

RCA VICTOR MODEL T 11-8

Eleven-Tube, Three-Band, A-C, Superheterodyne Table Receiver

SERVICE NOTES

Electrical Specifications

FREQUENCY RANGES

Band X.....	140 kc.— 410 kc.
Band A.....	540 kc.— 1,800 kc.
Band C.....	5,700 kc.—18,000 kc.

ALIGNMENT FREQUENCIES

Band X.....	150 kc. (osc.), 400 kc. (osc., ant., det.)
Band A.....	600 kc. (osc.), 1,720 kc. (osc., ant., det.)
Band C.....	18,000 kc. (osc., ant., det.)

Intermediate Frequency 460 kc.

RADIOTRON COMPLEMENT

- (1) RCA-6K7.....Radio-Frequency Amplifier
- (2) RCA-6L7.....First Detector
- (3) RCA-6J7.....Heterodyne Oscillator
- (4) RCA-6K7.....Intermediate Amplifier
- (5) RCA-6H6.....Second Detector and A.V.C.

- (6) RCA-6C5.....First Audio Amplifier
- (7) RCA-6C5.....Audio Driver Amplifier
- (8) RCA-6F6.....Power Output Amplifier
- (9) RCA-6F6.....Power Output Amplifier
- (10) RCA-5Z3.....Full-Wave Rectifier
- (11) RCA-6E5.....Tuning Indicator

POWER SUPPLY RATINGS

Rating A.....	105-125 volts, 50-60 cycles, 130 watts
Rating B.....	105-125 volts, 25-60 cycles, 135 watts
Rating C.....	100-130/140-160/195-250 volts, 40-60 cycles, 135 watts

POWER OUTPUT RATINGS

Undistorted Output.....	8.5 watts
Maximum Output.....	11.5 watts

LOUDSPEAKER

Type.....	8-inch Electrodynamic
Voice Coil Impedance.....	2¼ ohms at 400 cycles

Mechanical Specifications

Height.....	23 ³ / ₁₆ inches
Width.....	17 inches
Depth.....	13½ inches
Weight (Net).....	48 pounds
Weight (Shipping).....	60½ pounds
Chassis Base Dimensions.....	15½ inches x 10½ inches x 3½ inches

GENERAL FEATURES

This instrument comprises an eleven-tube chassis mounted in a table type of cabinet. Its tuning ranges cover the long wave, standard broadcast, short wave broadcast, amateur and aviation bands. The following points of design are of particular importance:

Metal Radiotrons

The new metal tubes are used in the radio receiver for amplifying and detecting purposes. These tubes make possible a greater range of stable amplification not previously attainable with corresponding glass types. Their metal envelopes form a perfect electrostatic and electromagnetic shield, precluding the former necessity for elaborate shielding by means of cans. The metal tubes are especially adaptable to the modern, extended-range receivers because of their efficient shielding and their favorable internal characteristics.

Tuning Condenser

The variable tuning condenser is supported by a new design of shock-proof mount which has been developed by our engineers to prevent chassis vibration from producing audio frequency howl.

Chassis

Servicing convenience has been a governing factor in the layout of the chassis parts and the associated wiring. Each part has been situated so that a minimum of wiring is necessary. Adjustments provided by means of substantial trimmers are mounted where they may be easily reached. Holes are included in the shield cans of the r-f coil system for testing the tuning with a Tuning Wand.

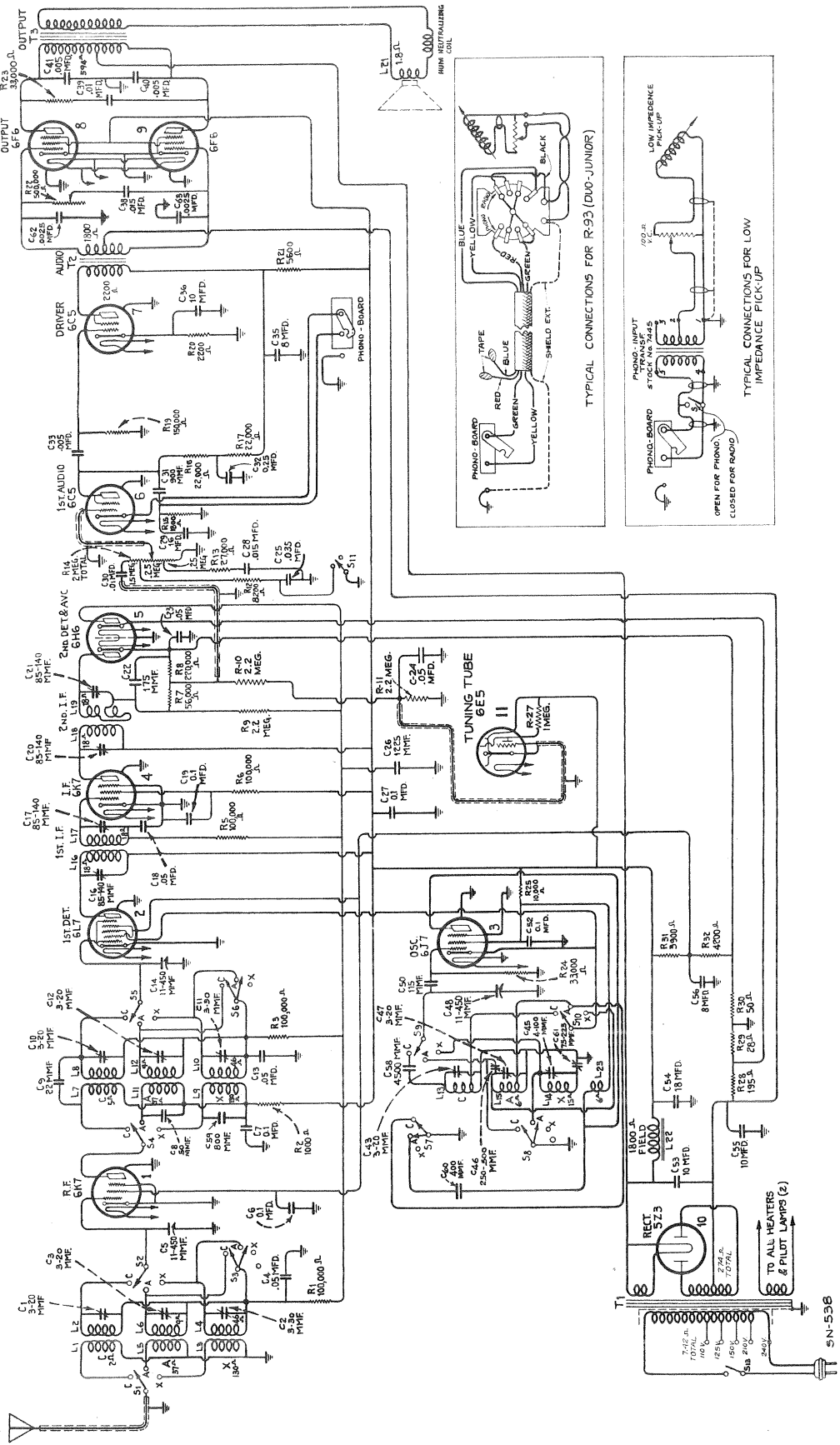

Figure 1—Schematic Circuit Diagram

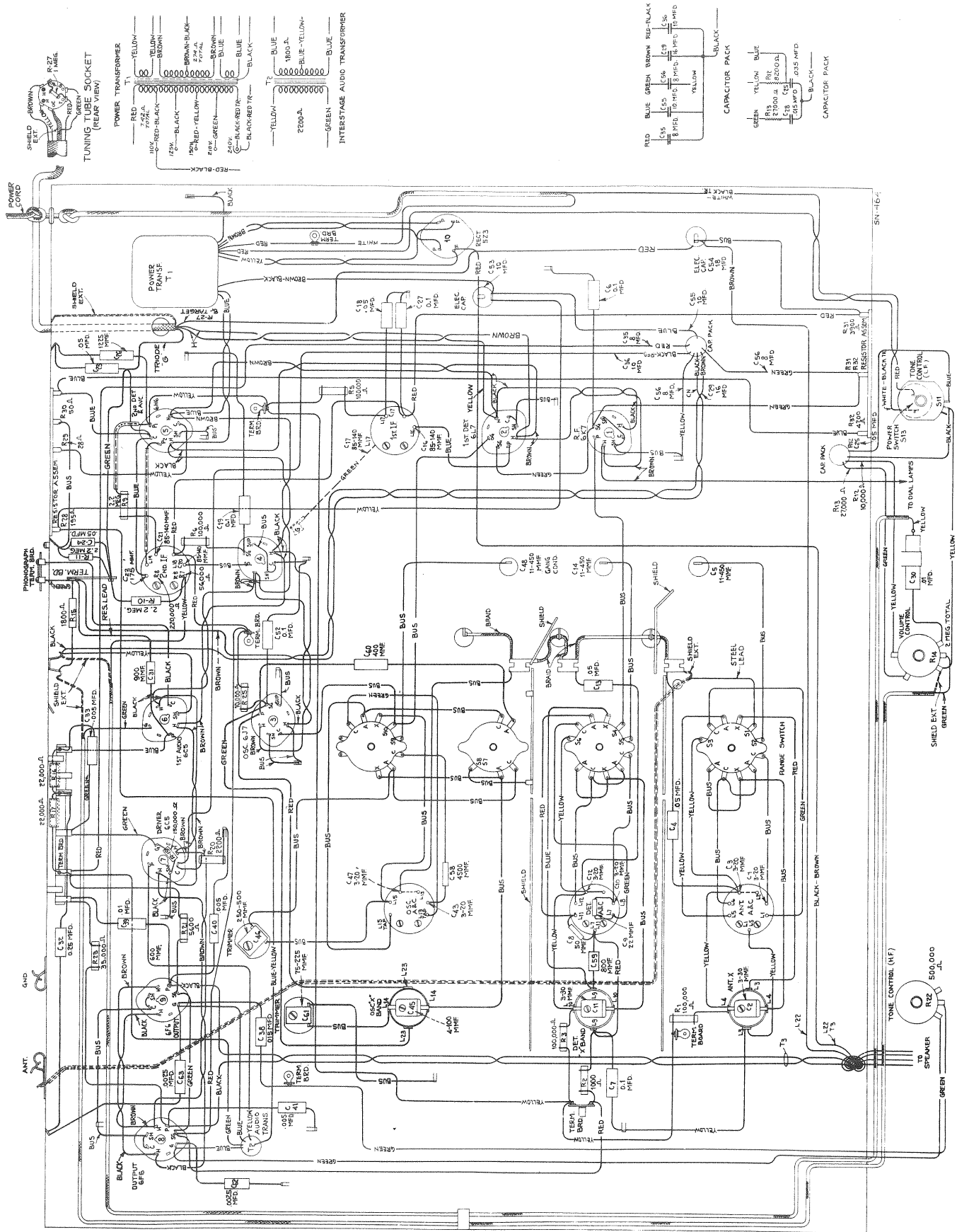

Figure 2—Chassis Wiring Diagram

Loudspeaker

An eight-inch, electrodynamic reproducer unit is used to handle the high level output of the receiver. The speaker is designed to operate in such manner with the acoustics of the cabinet that the best quality of reproduction is obtained. Connections from the chassis to speaker are made through a plug and connector, which permits either unit to be removed quickly for service.

CIRCUIT ARRANGEMENT

The Superheterodyne principle of operation forms the basis of the circuit design. A single, tuned r-f stage is used ahead of the first detector. The functions of oscillator and detector are performed by two separate tubes. One i-f stage is employed and designed to operate at 460 kc. The combined second detector and a.v.c. stage uses an RCA-6H6 double diode. The audio system consists of two single amplifier stages working in cascade with a push-pull power output stage. The loudspeaker is an electrodynamic type, receiving its field supply from the rectifier and filter system and simultaneously acting as a filter reactor. Full wave rectification is performed in the RCA-5Z3 tube. The outstanding features of electrical design are concerned with the following:

Tuned Circuits

A total of seven circuits are tuned to provide gain and selectivity to the incoming signal. The variable gang condenser resonates the antenna transformer secondary, the detector transformer secondary and the oscillator coil. Alignment trimmers are included for each of these same circuits. Additional trimmers are used on the i-f transformers, tuning both the secondaries and primaries to 460 kc. There are separate groups of antenna, detector and oscillator coils for each of the tuning ranges. They are placed into operation by means of a rugged rotary switch.

First Detector

This stage has unusually good high frequency mixing efficiency. The tube used, an RCA-6L7, is a new hexode type. The signal is supplied to the first control grid and the oscillator is fed in on a second control grid, a screen grid separating the two. The arrangement of the grids prevents degenerative difficulties, particularly at the higher frequencies. The second grid is direct-connected to the cathode of the oscillator tube and has no d-c bias.

Oscillator

The oscillator circuit is worthy of careful study inasmuch as it is different from the type ordinarily employed. It has self-stabilizing properties which are very advantageous for short wave operation. The generated frequency remains substantially constant, the circuit being unaffected by variation of line voltage and other similar influences. Output also remains uniform over the individual tuning ranges. The switching of the tuning coils is arranged so as to short those not in use in order to prevent absorption or any reactive effects in the particular band being tuned.

Color Band Dial

The station indicating dial is neatly designed with each scale identified by a different color. As the range switch is changed from one band to another, an index pointer moves so as to point to a short strip of color at the lower part of the dial to indicate the band being used. A push-in clutch arrangement gives a 10-to-1 or 50-to-1 drive ratio. The vernier pointer has a ratio of 20-to-1 with respect to the main pointer.

Detector and A.V.C.

The modulated signal as obtained from the output of the i-f system is detected by an RCA-6H6 double diode tube. The audio frequency secured by this process is passed on to the a-f system for amplification and final reproduction. The d-c voltage which results from detection of the signal, is used for automatic volume control. This voltage, which develops across resistors R-7 and R-8, is applied as automatic control grid bias to the r-f, first detector and i-f tubes through suitable resistance-capacitance filter circuits. The second diode of the RCA-6H6 is used to supply residual bias for these controlled tubes under conditions of little or no signal. This diode, under such conditions, draws current, which flows through resistors R-7, R-8 and R-9, thereby maintaining the desired minimum

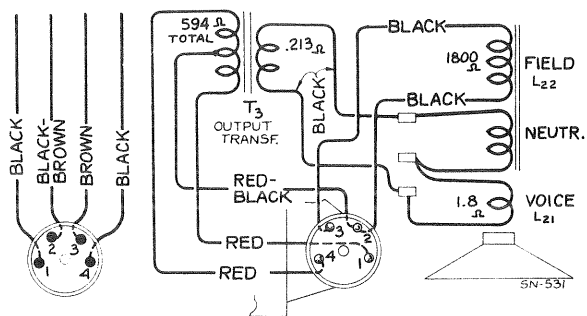

Figure 3—Loudspeaker Wiring

operating bias on such tubes. On application of signal energy above a certain level, however, the auxiliary bias diode ceases to draw current and the a.v.c. diode takes over the biasing function. The cathode and anode of the signal-a.v.c. diode have positive potential in respect to chassis-ground and cathodes of the a.v.c. controlled tubes when no signal is being received.

Audio System

Manual volume control of the detected signal is effected by an acoustically tapered potentiometer in the grid circuit of the first a-f stage. This control has tone compensating filters connected to two points thereon. These filters effect the correct aural balance at different volume settings. A music-speech switch (low frequency tone control) is associated with one of the compensation filters. The purpose of this control is to make speech reproduction more intelligible and to reduce hum obtained from stray modulation on a carrier. The driver stage of the audio system uses an

RCA-6C5 which is resistance coupled to the first a-f tube and transformer coupled into the push-pull power output stage.

Tuning Indicator

A cathode-ray tube is used as a means of visually indicating when the receiver is accurately tuned to the incoming signal. This tube is of new design and comprises an amplifier section and a cathode-ray

section built in the same glass envelope. The cathode-ray section consists of a conically shaped luminescent screen, upon which a pattern is formed by an effect of the detected signal after said effect has been amplified by the amplifier section which is fed from the detector diode circuit. The size of the pattern is determined by the strength of the signal voltage, so that any change of tuning may be readily observed in order to facilitate tuning to exact resonance.

SERVICE DATA

The various diagrams of this booklet contain such information as will be needed to isolate causes for defective operation when such develops. The ratings of the resistors, capacitors, coils, etc., are indicated adjacent to the symbols signifying these parts on the diagrams. Identification titles such as R-3, L-2, C-1, etc., are provided for reference between the illustrations and the Replacement Parts List. The coils, reactors, and transformer windings are rated in terms of their d-c resistances only. Ratings of less than one ohm are generally omitted.

Alignment Procedure

Eleven alignment trimmers are provided in the r-f, first detector and oscillator tuning system and four are used in the i-f system. All of these are accurately adjusted during manufacture and should remain in proper alignment unless affected by abnormal conditions of climate or have been altered by other means. Loss of sensitivity, improper tone quality and poor selectivity are the usual indications of improper alignment.

Correct performance of the receiver can only be obtained when the trimmer adjustments have been made by a skilled service man with the use of adequate and reliable test equipment. Such apparatus as may be required for alignment of this particular instrument is illustrated and described on a separate page of this booklet.

Two methods of alignment are applicable. One utilizes a Cathode-Ray Oscillograph as a means of output indication and the other follows former procedure where a glow type indicator or meter is used. The oscillographic method is much to be preferred, since greater accuracy is possible from the type of indication afforded. There are no approximations necessary as with the meter or aural method, but each adjustment can be made with definite precision. Both methods are hereinafter outlined so that alignment operations may be made according to the equipment available.

It is wise to determine the necessity for alignment as well as the direction of misalignment before making adjustments. The RCA Tuning Wand is an instrument designed particularly for such a purpose.

The Tuning Wand consists of a bakelite rod having a small brass cylinder at one end and a core of finely divided iron at the other. It may be inserted into a tuned coil while a signal of the normal resonant frequency is being supplied to such coil to obtain an indication of the tuning. Holes are provided at the top of the r-f shield cans for entrance of the Wand. The presence of either end of the Wand will cause a change in tuning which will be indicated at the receiver output as an increase or decrease in signal level. If there is

a decrease of output when either end is inserted, the tuning is correct and will require no adjustment. However should there be an increase of output due to the iron core and decrease with the brass cylinder, an increase in inductance or capacitance is indicated as necessary to bring the circuit into line. The trimmer involved should therefore be increased accordingly. If the brass cylinder end causes an increase in output while the iron end causes a decrease, reduction of inductance will be necessary to place the circuit in alignment. This is equivalent to decreasing the trimmer concerned. The following tabulation gives the various changes and the adjustments required:

WAND	SIGNAL	TRIMMER
{ Brass.....	Decrease }	None
{ Iron.....	Decrease }	None
{ Brass.....	Increase }	Decrease
{ Iron.....	Decrease }	Decrease
{ Brass.....	Decrease }	Increase
{ Iron.....	Increase }	Increase

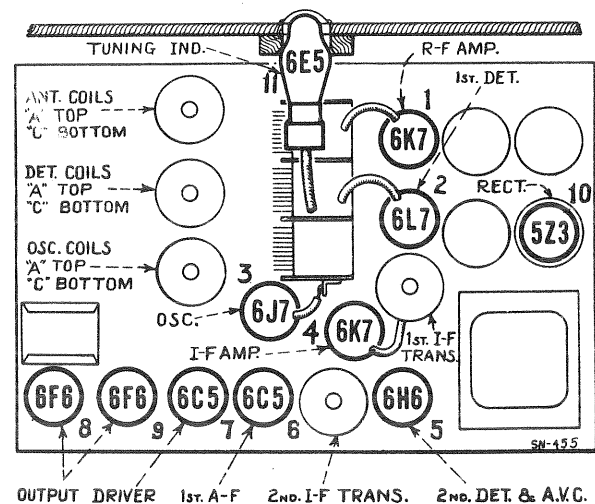

Figure 4—Radiotron and Coil Locations

CATHODE-RAY ALIGNMENT

Equipment

A standard source of alignment frequencies is required. Such a source should consist of an RCA Full Range Oscillator, Stock No. 9595. Output indication should be by means of an RCA Stock No. 9545 Cathode-Ray Oscillograph. An RCA Stock No. 9558 Frequency Modulator will be needed to sweep the generated signal and synchronize it with the Oscillograph in order to obtain visual representation of the resonant characteristic of the circuit being tuned on the cathode-ray fluorescent screen.

I-F Trimmer Adjustments

The four trimmers of the two i-f transformers are located as shown by Figure 6. Each must be aligned

to a basic frequency of 460 kc. The last transformer must be aligned firstly and the first transformer aligned secondly. For such a process, it is necessary to feed the output of the Full Range Oscillator to the stages in their order of alignment, adjusting the trimmers of each transformer and observing the effect at the second detector output on the Cathode-Ray Oscillograph. The proper point of connection of the Oscillograph is with its vertical "high" input terminal attached to the juncture of R-7 and R-8, as illustrated in Figure 6, and with the "0" or ground terminal to the chassis. The "Ext. Sync." terminals of the Oscillograph should be connected to the Frequency Modulator as shown by Figure 5. A .001 mfd. capacitor installed in series with the Oscillator "Ant." lead will prevent the voltages of the stage under alignment from becoming upset. The vertical "A" amplifier should be "On" for the ensuing adjustments

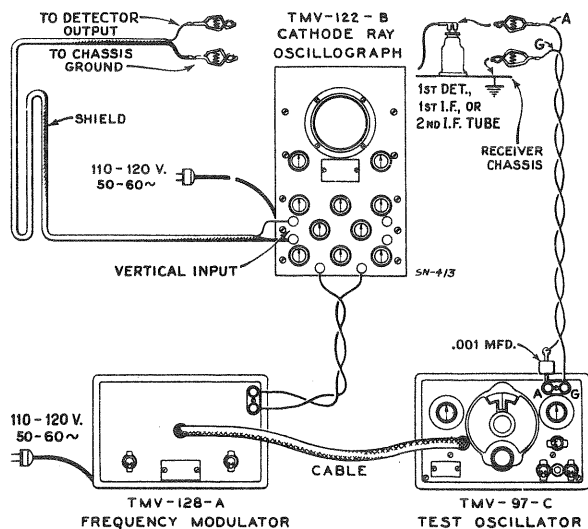

Figure 5—Alignment Apparatus Connections

and its gain control kept at maximum. For each adjustment, the Oscillator output must be regulated so that the image obtained on the Oscillograph screen will be of the minimum size convenient for accurate observation. Proceed further as follows:

- (a) Place the receiver, Oscillograph and test Oscillator in operation. Set the receiver range switch to Band "A" and tune the station selector to a point where no interference will be encountered from signal pickup or from the RCA-6J7 oscillator, removing the tube if necessary. Set the Oscillograph horizontal "B" amplifier to "Timing" and control its gain so that the luminescent spot sweeps a straight line trace completely across the screen. Place the timing control to "Int." Adjust the intensity and focusing controls of the Oscillograph to produce the correct size and strength of spot.
- (b) Attach the output of the test Oscillator between the control grid cap of the RCA-6K7 i-f tube and chassis ground as shown typically by Figure 5. Tune the Oscillator to 460 kc. and set its modulation switch to "On." Regu-

late its output until the signal produces a wave pattern on the Oscillograph screen, adjusting the Oscillograph controls to give a shape which is convenient for peak indications. Cause the image to stand still on the screen by manipulation of the frequency and synchronizing controls. Then carefully tune the two trimmers C-20 and C-21 of the second i-f transformer to produce maximum amplitude (vertical deflection) of the oscillographic image. Under this condition the transformer will be sharply resonated to 460 kc.

- (c) The Frequency Modulator should then be placed in operation and interconnected with the Full Range Oscillator by means of the special shielded patch cord. Figure 5 shows the proper arrangement. Set the Frequency Modulator sweep range switch to its "Lo" position and turn the Oscillator modulation switch to "Off." Change the timing control of the Oscillograph to "Ext." and place the range switch to its No. 2 position. Then carefully shift the tuning of the Oscillator so as to increase its frequency, until two distinct and similar waves appear on the Oscillograph screen and become exactly co-incident at their highest points. This condition will be found to occur at an Oscillator setting of approximately 540 kc. The curves will be identical in shape but appearing in reversed positions. Adjust the frequency control of the Oscillograph in order to cause the waves to conform with the above requirement and to make them remain motionless on the screen. This will require a setting of approximately $\frac{1}{2}$ clockwise rotation of the frequency control. The trimmers C-20 and C-21 should then be re-adjusted so that the two curves move together and become exactly coincident throughout their lengths, maintaining the maximum amplitude at which this condition can be brought about.
- (d) Leaving the equipment connected and adjusted as in (c), change the Oscillator output to the control grid cap of the RCA-6L7 first detector tube. Then adjust the first i-f transformer trimmers C-16 and C-17 so that the forward and reverse waves appearing on the Oscillograph coincide throughout their lengths and have maximum amplitude. The shape of the composite wave obtained from this operation is a true representation of the overall tuning characteristic of the i-f system.

R-F Trimmer Adjustments

For Bands A and X, adjustments must be made at the high and low frequency ends of the range. On Band C, alignment is required only at the high frequency end.

Locations of the various antenna, detector and oscillator coil trimmers are shown by Figure 6. The test Oscillator should be removed from connection with the i-f system and its output connected to the antenna-ground terminals of the receiver. No changes are to be made in the connections of the Oscillograph

at the second detector. During the following adjustments, the Oscillator output should be regulated as often as is necessary to keep the oscillographic image as low as is practically observable. Adherence to this procedure will obviate the broadness of tuning that would result from a.v.c. action on a stronger signal. Proceed with the adjustments as follows:

CALIBRATION

Set the receiver range switch to Band A and rotate the station selector until the tuning condenser plates are in full mesh (maximum capacitance). Then move the main dial pointer until it points exactly to the horizontal line at the low frequency end of the Band A scale. Correct the setting of the vernier second hand pointer to read zero.

BAND A

(a) With the receiver range switch in its Band A position, tune the station selector until the dial pointer is at a reading of 1720 kc. Adjust the test Oscillator to 1720 kc. (modulation "On" and Frequency Modulator disconnected) and increase its output to produce a registration on the Oscillograph. Carefully align the oscillator, detector and antenna trimmers, C-47, C-12 and C-3 respectively, so that each brings about maximum amplitude of output as shown by the wave on the Oscillograph. It will be necessary to have the timing control of the Oscillograph on "Int." for this operation. After each trimmer has been peaked, the Oscillograph timing control should be set to "Ext." and the Frequency Modulator placed into operation with its connections to the

Oscillator and Oscillograph made in accordance with Figure 5. Turn the modulation switch of the Oscillator to "Off" and retune the Oscillator (increase frequency) until the forward and reverse waves show on the Oscillograph and become coincident at their highest points. Adjust the trimmers C-47, C-12 and C-3 again, setting each to the point which produces the best coincidence and maximum amplitude of the wave images.

(b) Remove the Frequency Modulator cable from the Oscillator and shift the signal frequency to 600 kc. Place the modulation switch to "On". Tune the receiver to pick up this signal, disregarding the dial reading at which it is best received. Then insert the Frequency Modulator plug and retune the Oscillator (modulation "Off") until the two similar forward and reverse waves appear on the screen. For this adjustment, it is advisable to shift the Oscillator to its 200-400 kc. range using the third harmonic of the generated signal in order to obtain the desired range of sweep. The oscillator series trimmer, C-46, should then be adjusted to produce maximum amplitude of the images. No rocking will be necessary on the station selector inasmuch as the signal frequency is being "wobbled" by the Frequency Modulator to produce the same effect. After completing this adjustment, the trimmer C-47 should be re-aligned as in (a) to correct for any change brought about by the adjustment of C-46.

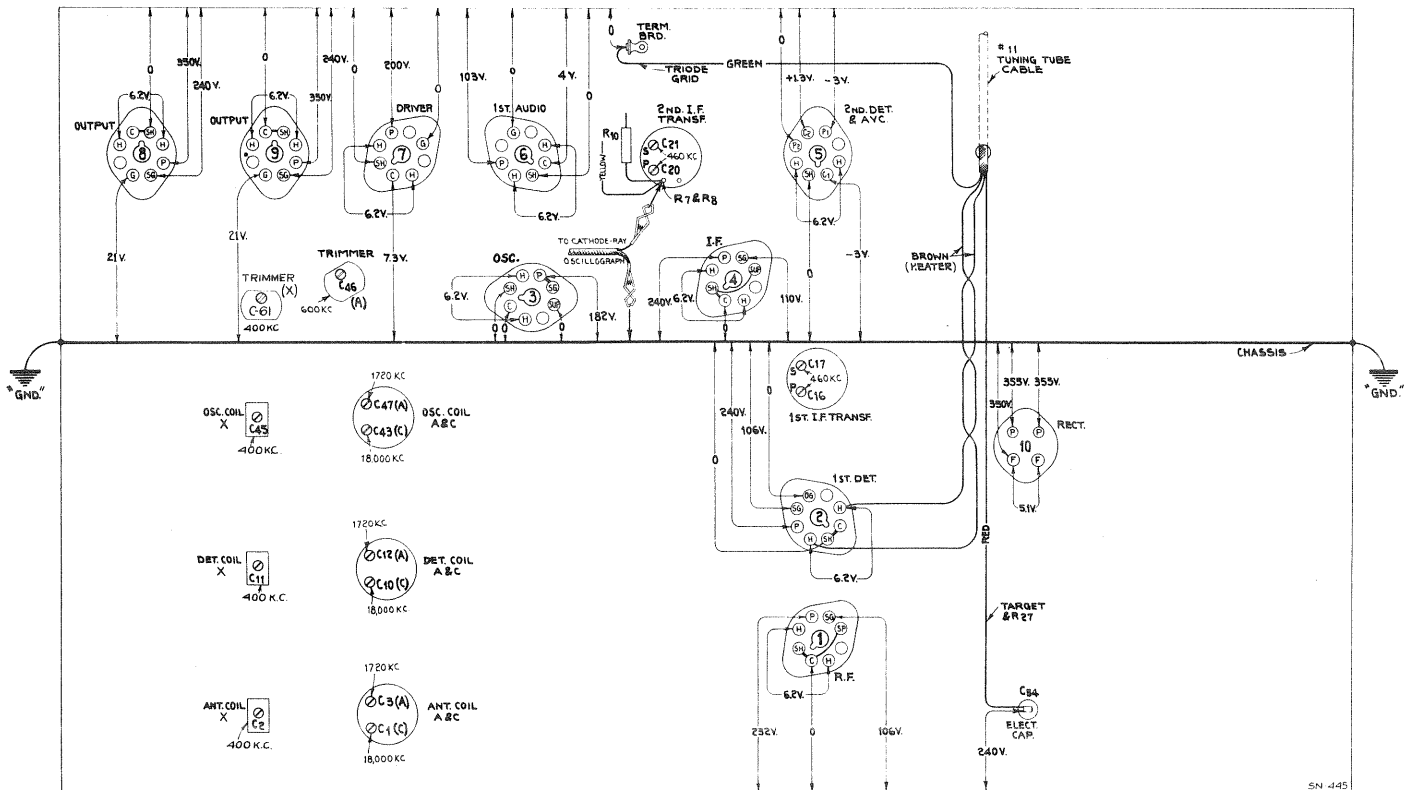

Figure 6—Trimmer Locations and Radiotron Socket Voltages
Measured at 115 volts, 60 cycles—No signal input

BAND X

- (a) Disconnect the Frequency Modulator and tune the test Oscillator to a frequency of 400 kc. (Modulation "On"). Place the receiver range switch in its Band X position and turn the station selector until the dial pointer reads 400 kc. Adjust the Oscillograph timing control to "Int." Then align each of the trimmers C-45, C-11 and C-2 to the point producing maximum output at the Oscillograph. Place the Frequency Modulator in operation and attach it to the Oscillator in the normal manner. Change the Oscillograph timing to "Ext." Increase the frequency of the Oscillator (modulation "Off") until the two waves appear and become coincident at their highest points, approximately at 462 kc. They may be made to remain stationary on the screen by manipulation of the Oscillograph range switch and frequency control. Readjust the three trimmers C-45, C-11 and C-2 to give maximum amplitude and complete coincidence of the waves.
- (b) Change the test Oscillator so that it delivers a signal of 150 kc. with the Frequency Modulator disconnected. Tune this signal on the receiver which has previously been set to Band X, disregarding the dial reading at which the signal is best received. Then interconnect the Frequency Modulator with the Oscillator and retune the latter to the point at which the two similar waves appear on the screen. Adjust trimmer C-61, for maximum amplitude of the wave images. Rocking of the tuning condenser will not be necessary as the Frequency Modulator duplicates such an operation. Repeat the alignment of C-45 as outlined in (a) to correct for any reflective error brought about by the adjustment of C-61.

BAND C

- (a) Turn the range switch of the receiver to its Band C position and tune the station selector until the dial pointer reads 18,000 kc. Set the test Oscillator to the same frequency (modulation "On" and Frequency Modulator disconnected) and regulate its output to the level required for convenient observation. Adjust the trimmer C-43 to the point producing maximum output as indicated on the Oscillograph. Check for the presence of the proper "image" signal by tuning the receiver to 17,080 kc. The 18,000 kc. signal of the Oscillator will be received at this point if the adjustment of C-43 has been properly made by using the position of least capacitance which gives maximum receiver output. It may be necessary to increase the output of the Oscillator in order to get an indication of the "image". *No adjustments should be made during this check.*
- (b) Return the receiver tuning to 18,000 kc., realign C-43 if necessary, and then adjust the detector and antenna trimmers, C-10 and C-1, for maximum signal output as evidenced by the oscillographic image. No further adjustments are to be made on this band.

OUTPUT INDICATOR ALIGNMENT

To align the receiver by means of an output indicator other than a Cathode-Ray Oscillograph will require the use of a standard test Oscillator, such as that recommended above, for the source of signals and means of indication for the output. The RCA Neon Output Indicator, Stock No. 4317, will be found very satisfactory for such use. It should be connected across the voice coil circuit of the loudspeaker or across the output transformer primary.

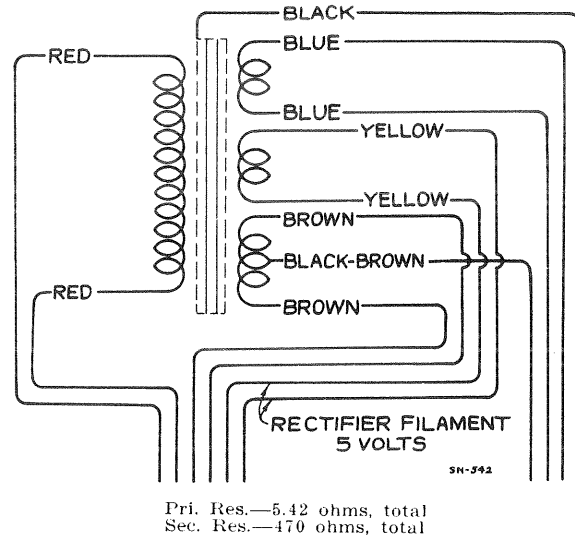

Figure 7—Standard Power Transformer Connections

I-F Alignment

Connect the test Oscillator to the control grid cap of the i-f tube. Advance the volume control of the receiver to its full-on position. Tune the test Oscillator accurately to 460 kc. and align the trimmers C-20 and C-21 to give maximum receiver output. Regulate the Oscillator output during this adjustment so that the output indication is as small as can be conveniently observed. After completing the adjustments of these trimmers, re-connect the Oscillator so that it will feed into the control-grid circuit of the RCA-6L7 first detector. Then tune the first i-f transformer trimmers C-16 and C-17 for maximum receiver output.

R-F Alignment

After completing the i-f adjustments, it is advisable to correct the line-up of the circuits ahead of the first detector. The test Oscillator should be connected to the antenna-ground terminals of the receiver and the manual volume control turned to its maximum position. For each adjustment, the Oscillator output should be maintained as low as possible in order to avoid broadness of tuning which would result from a.v.c. action on a stronger signal.

Band A—This band should be aligned by supplying a 1720 kc. signal to the receiver, tuning the station selector to a dial reading of 1720 and adjusting the trimmers C-47, C-12 and C-3 to produce maximum receiver output. The Oscillator should then be shifted to 600 kc. and the receiver tuned to resonate this signal, disregarding the reading at which

it is best received. Trimmer C-46 must then be adjusted, simultaneously while rocking the station selector backward and forward through the signal until the maximum output results from the combined operations. C-47 should be rechecked to assure that its adjustment has not changed because of the trimming of C-46.

Band X—Change the range switch to its Band "X" position. Tune the receiver to read 400 kc. and set the Oscillator to 400 kc. Adjust trimmers C-45, C-11 and C-2 to produce maximum receiver output. Then shift the Oscillator frequency to 150 kc. and tune the receiver to pick up this signal, disregarding the dial reading at which it is best received. Then tune the oscillator series trimmer, C-61, simultaneously rocking the tuning control (receiver) backward and forward through the signal, until maximum output results from the combined operations. Repeat the alignment of C-45 as in (a) to correct for any change caused by the adjustment of C-61.

Band C—Change the receiver so that it is operative and the dial reads 18,000 kc. on the "C" Band. Tune the test Oscillator to this same frequency. Then adjust the oscillator trimmer C-43 to produce maximum (peak) output. Two positions of this trimmer will be found which conform with this requirement. The one of least capacitance is correct. Check for the presence of "image" response at 17,080 kc. by shifting the receiver tuning. If it is received at such a point, the trimmer C-43 has been correctly adjusted to the right peak. *No adjustments are to be made during this check.* Tune the receiver back to the

18,000 kc. dial marking, readjust C-43 if necessary, and then tune the detector and antenna capacitors C-10 and C-1 for maximum receiver output. No further adjustments are necessary.

Radiotron Socket Voltages

The voltage values indicated from the Radiotron socket contacts to chassis on Figure 6 will serve to assist in the location of causes for faulty operation. Each value as specified should hold within $\pm 20\%$ when the receiver is normally operative at its rated supply voltage. Variations in excess of this limit will usually be indicative of trouble in the basic circuits. The voltages given are actual operating values and do not allow for inaccuracies which may be caused by the loading effect of a voltmeter's internal resistance.

Standard Transformer

The transformer used on some models of this instrument is adaptable for voltages and frequencies as given under Ratings A and B of Electrical Specifications. Its schematic and wiring are shown by Figure 7.

Phonograph Attachment

A terminal board is provided for connecting a phonograph attachment into the audio amplifying circuit. Two typical methods of connection are shown on the schematic diagram Figure 1. The radio volume control must be set to minimum when using phonograph.

REPLACEMENT PARTS

Insist on genuine factory tested parts, which are readily identified and may be purchased from authorized dealers

STOCK No.	DESCRIPTION	LIST PRICE	STOCK No.	DESCRIPTION	LIST PRICE
RECEIVER ASSEMBLIES					
4632	Board—Terminal board assembly—two terminals	\$0.25	11203	Capacitor—10 Mfd. (C53).....	1.18
4427	Bracket—Volume control mounting bracket18	5212	Capacitor—18 Mfd. (C54).....	1.16
5237	Bushing—Variable tuning condenser mounting bushing assembly—comprising one bushing, one washer, one lock-washer and one nut—Package of 3....	.43	11215	Capacitor pack—Comprising one 16 Mfd., two 10 Mfd., and two 8 Mfd. capacitors (C29, C35, C36, C55, C56).....	3.85
11223	Capacitor—Adjustable capacitor (C46)....	.46	4693	Clamp—Electrolytic condenser mounting clamp—for stock No. 11215.....	.15
5241	Capacitor—Adjustable capacitor (C61)....	.40	11325	Coil—Antenna coil—X band (L3, L4, C2)	1.56
11292	Capacitor—22 MMfd. (C9).....	.24	11326	Coil—Detector coil—X band (L9, L10, C11)	1.60
11289	Capacitor—50 MMfd. (C8).....	.26	11327	Coil—Oscillator coil—X band (L14, L23, C45)	1.44
11291	Capacitor—115 MMfd. (C50).....	.24	5215	Coil—Antenna coil—A and C bands (L1, L2, L5, L6, C1, C3).....	2.32
11290	Capacitor—400 MMfd. (C60).....	.25	5216	Coil—Detector coil—A and C bands (L7, L8, L11, L12, C10, C12).....	2.34
11269	Capacitor—800 MMfd. (C59).....	.30	5217	Coil—Oscillator coil—A and C bands (L13, L15, C43, C47).....	2.20
3784	Capacitor—900 MMfd. (C31).....	.30	11277	Compensating Pack—Comprising one 8200 ohm and one 27,000 ohm resistors, one .015 Mfd., one .035 Mfd. capacitors (C25, C28, R12, R13).....	.92
11316	Capacitor—1225 MMfd. (C26).....	.40	11214	Condenser—Three-gang variable tuning condenser (C5, C14, C48).....	4.20
11287	Capacitor—4500 MMfd. (C58).....	.30	11697	Cover—Terminal board cover.....	.12
5107	Capacitor—.0025 Mfd. (C62, C63).....	.16	11202	Foot—Chassis foot and bracket assembly—Package of 2.....	.78
4838	Capacitor—.005 Mfd. (C40, C41).....	.20	11710	Lead—Shielded lead—connects antenna terminal to range switch.....	.40
4868	Capacitor—.005 Mfd. (C33).....	.20			
4624	Capacitor—.01 Mfd. (C30).....	.54			
4937	Capacitor—.01 Mfd. (C39).....	.25			
11315	Capacitor—.015 Mfd. (C38).....	.20			
4836	Capacitor—.05 Mfd. (C4, C13, C18, C23)	.30			
4886	Capacitor—.05 Mfd. (C24).....	.20			
4839	Capacitor—0.1 Mfd. (C7, C19, C27, C52)	.28			
4841	Capacitor—0.1 Mfd. (C6).....	.22			
5170	Capacitor—0.25 Mfd. (C32).....	.25			

The prices quoted above are subject to change without notice.

REPLACEMENT PARTS—Continued

STOCK No.	DESCRIPTION	LIST PRICE	STOCK No.	DESCRIPTION	LIST PRICE
8041	Plate—I. F. or R. F. coil shield locking plate—Package of 2.....	.12	11303	Indicator—Station selector vernier indicator pointer.....	.22
11220	Resistor—Voltage divider resistor—Comprising one 3900 ohm and one 4200 ohm sections (R31, R32).....	.84	11226	Indicator—Band indicator pointer assembly—comprising indicator, arm, link and stud.....	.20
11221	Resistor—Voltage divider resistor—Comprising one 50 ohm, one 28 ohm and one 195 ohm sections (R28, R29, R30)	.48	4475	Indicator—Station selector indicator.....	.18
5112	Resistor—1000 ohm—Carbon type— $\frac{1}{4}$ watt (R2)—Package of 5.....	1.00	4340	Lamp—Dial lamp—Package of 5.....	.60
3706	Resistor—1800 ohm—Carbon type— $\frac{1}{4}$ watt (R15)—Package of 5.....	1.00	3993	Screw—No. 6-32-5/32-in. set screw for band indicator operating arm—Package of 10.....	.25
5159	Resistor—2200 ohm—Carbon type— $\frac{1}{4}$ watt (R20)—Package of 5.....	1.00	4669	Screw—No. 8-32-5/32-in. square head set screw—for tuning condenser shaft—Package of 10.....	.25
5175	Resistor—5600 ohm—Carbon type— $\frac{1}{2}$ watt (R21)—Package of 5.....	1.00	4377	Spring—Band indicator operating arm spring—Package of 5.....	.25
2731	Resistor—10,000 ohm—Carbon type—1 watt (R25)—Package of 5.....	1.10	4378	Stud—Band indicator operating arm stud assembly—Package of 5.....	.25
11305	Resistor—22,000 ohm—Carbon type— $\frac{1}{4}$ watt (R16, R17)—Package of 5.....	1.00	REPRODUCER ASSEMBLIES		
5033	Resistor—33,000 ohm—Carbon type—1 watt (R23)—Package of 5.....	1.10	11232	Board—Terminal board with two lead wire clips.....	.18
11300	Resistor—33,000 ohm—Carbon type— $\frac{1}{10}$ watt (R24)—Package of 5.....	.75	11231	Bolt—Yoke and core assembly bolt and nut.....	.16
3118	Resistor—100,000 ohm—Carbon type— $\frac{1}{4}$ watt (R1, R3, R5, R6)—Package of 5.	1.00	8060	Bracket—Mounting bracket for output transformer and connector.....	.14
5027	Resistor—150,000 ohm—Carbon type— $\frac{1}{4}$ watt (R19)—Package of 5.....	1.00	11304	Cable—Reproducer cable—Complete with female connector.....	.80
11626	Resistor—2.2 megohms—Carbon type— $\frac{1}{4}$ watt (R9, R10, R11)—Package of 5..	1.00	11257	Clamp—Cone center suspension clamping nut and screw assembly—Package of 5.	.25
5249	Shield—Antenna, detector, or oscillator coil shield.....	.20	11234	Coil—Field coil (L-22).....	2.15
5250	Shield—Intermediate frequency transformer shield.....	.22	11233	Coil—Neutralizing coil.....	.30
11222	Socket—Dial lamp socket.....	.18	11235	Cone—Reproducer cone (L21)—Package of 5.....	3.50
4794	Socket—4-contact rectifier Radiotron socket.....	.15	5040	Connector—4 contact female connector socket for reproducer cable.....	.25
11197	Socket—6-contact Radiotron socket.....	.14	5039	Connector—4 prong male connector plug for reproducer.....	.25
11198	Socket—7-contact Radiotron socket.....	.15	9617	Reproducer—Complete.....	6.60
11236	Switch—Range switch (S1, S2, S3, S4, S5, S6, S7, S8, S9, S10).....	2.44	11229	Transformer—Output transformer (T3)..	1.66
5224	Switch—Low frequency tone control and power switch (S11, S13).....	1.00	11230	Washer—Binders board "C" washer—used to hold field coil securely—Package of 5	.18
5238	Terminal—Antenna terminal board with clip, insulating strip and rivets.....	.14	MISCELLANEOUS ASSEMBLIES		
11219	Tone Control—High frequency tone control (R22).....	.90	11729	Bolt—Reproducer mounting bolt assembly—Comprising one bolt, one washer, one lockwasher and one nut—Package of 2.	.20
11218	Transformer—Audio driver transformer (T2).....	2.58	11191	Bracket—Tuning lamp mounting bracket—less clamp.....	.12
11216	Transformer—First intermediate frequency transformer (L16, L17, C16, C17)....	2.15	11319	Cable—Tuning tube cable—complete with socket.....	1.38
11217	Transformer—Second intermediate frequency transformer (L18, L19, C20, C21, C22, R7, R8).....	3.10	11192	Clamp—Tuning lamp mounting clamp—less bracket.....	.12
11212	Transformer—Power transformer—105-125 volts—25-50 cycles.....	7.18	11276	Escutcheon—Tuning lamp escutcheon..	.40
11213	Transformer—Power transformer—250-210-150-125-105 volts—40-60 cycles (T1).....	5.10	11337	Escutcheon—Station selector escutcheon..	.70
11205	Volume Control—(R14).....	1.30	6614	Glass—Station selector dial glass.....	.30
DRIVE ASSEMBLIES			11347	Knob—Volume control, tone control, range switch or power switch knob—Package of 5.....	.75
4362	Arm—Band indicator operating arm.....	.28	11346	Knob—Station selector knob—Package of 5.....	.75
10194	Ball—Steel ball—Package of 20.....	.25	11382	Resistor—1 megohm—Carbon type— $\frac{1}{10}$ watt (R27)—Package of 5.....	.75
4422	Clutch—Tuning condenser drive clutch assembly—Comprising drive shaft, balls, ring, spring and washers, assembled...	1.00	4678	Ring—Spring retaining ring for station selector dial glass—Package of 5.....	.34
11333	Dial—Station selector dial scale.....	.60	11377	Screw—Chassis mounting screw assembly—Comprising one screw, one washer and one lockwasher—Package of 4....	.12
11227	Drive—Variable tuning condenser drive complete—less dial scale.....	2.08	11348	Screw—No. 8-32— $\frac{7}{16}$ -in. headless cupped point set screw for knob (Stock No. 11346)—Package of 10.....	.32
11228	Gear—Vernier pointer drive gear.....	.42	11381	Socket—Tuning tube socket and cover...	.45
4827	Gear—Spring gear assembly—complete—comprising stud, spring, cover, gears, mounting arm with screws and washers.	1.25	11349	Spring—Retaining spring for knob (Stock No. 11347)—Package of 5.....	.15

The prices quoted above are subject to change without notice.