

RCA VICTOR MODELS 6T10, 6K10, 8T10, AND 9K10

Technical Information and Service Data

(Issued as a supplement to Service Data

for Models 6T2, 6K2, 8T, and 9K2)

These instruments are similar to Models 6T2, 6K2, 8T, and 9K2 respectively except for cabinet design. The cabinets for these receivers have chromium trimmings which include tubular-steel support rails. Each Model is separately described below.

MODELS 6T10 and 6K10

The chassis and speakers for these instruments are identical to Models 6T2 and 6K2 (first production) respectively. All Service Data for Models 6T2 and 6K2 are directly applicable to these instruments except the Replacement Parts for Miscellaneous Assemblies which are listed below.

REPLACEMENT PARTS
6T10 - 6K10

Insist on genuine factory tested parts, which are readily identified and may be purchased from authorized dealers.

STOCK NO.	DESCRIPTION
	MISCELLANEOUS ASSEMBLIES
13303	CRYSTAL - Station selector escutcheon and crystal
13304	KNOB - Large station selector knob Model 6T10 only
13395	KNOB - Large station selector knob Model 6K10 only
13305	KNOB - Small (vernier) station selector knob - Model 6T10 only
13396	KNOB - Small (vernier) station selector knob - Model 6K10 only
13306	KNOB - Tone control, volume control, or range-switch knob - Model 6T10 only
13278	KNOB - Tone control, volume control, or range-switch knob - Model 6K10 only
11210	SCREW - Chassis mounting screw assembly - Model 6K10 only
11377	SCREW - Chassis mounting screw assembly - Model 6T10 only
4982	SPRING - Retaining spring for knob Stock No. 13304 and 13395
11349	SPRING - Retaining spring for knob Stock No. 13278, 13305, 13306, and 13396

MODEL 8T10

The chassis and speaker for this instrument are identical to Model 8T. All Service Data for Model 8T are directly applicable to these instruments except the Replacement Parts for Miscellaneous Assemblies which are listed below.

REPLACEMENT PARTS

8T10

STOCK NO.	DESCRIPTION
MISCELLANEOUS ASSEMBLIES	
11996	BRACKET - Tuning tube mounting bracket and clamp
13303	CRYSTAL - Station selector escutcheon and crystal
13275	ESCUTCHEON - Tuning tube escutcheon
13315	KNOB - Large station selector knob
13316	KNOB - Small (vernier) station selector knob
13317	KNOB - Volume control, tone control, or range switch knob
11377	SCREW - Chassis mounting screw assembly
4982	SPRING - Retaining spring for knob Stock No. 13315
11349	SPRING - Retaining spring for knob Stock No. 13316, and 13317

MODEL 9K10

The chassis and speaker for this instrument are identical to Model 9K2. All Service Data for Model 9K2 are directly applicable to these instruments except the Replacement Parts for Miscellaneous Assemblies which are listed below.

REPLACEMENT PARTS

9K10

STOCK NO.	DESCRIPTION
MISCELLANEOUS ASSEMBLIES	
11996	BRACKET - Tuning tube bracket and clamp assembly
13274	CRYSTAL - Station selector escutcheon and crystal
13275	ESCUTCHEON - Tuning tube escutcheon
13278	KNOB - Low-frequency tone control and power switch, volume control, range switch or high-frequency tone control knob
13276	KNOB - Large station selector knob
13277	KNOB - Small (vernier) station selector knob
11210	SCREW - Chassis mounting screw assembly
12916	SHIELD - R.F. unit top shield
11349	SPRING - Retaining spring for knob Stock No. 13277 and 13278
4982	SPRING - Retaining spring for knob Stock No. 13276

SERVICE DIVISION
RCA MANUFACTURING CO., INC.,
CAMDEN, N. J., U.S.A.

RCA VICTOR MODELS 6M AND 6M2

Six-Tube, Superheterodyne Automobile Receivers

Technical Information

Electrical Specifications

RADIOTRON COMPLEMENT

- | | |
|---|---|
| (1) RCA-6D6.....Radio-Frequency Amplifier | (4) RCA-85.....Second Detector, A-F, and A.V.C. |
| (2) RCA-6A8.....First Detector-Oscillator | (5) RCA-6C5.....Driver |
| (3) RCA-6K7.....Intermediate Amplifier | (6) RCA-6A6.....Power Output Amplifier |

Tuning Range 540 to 1,600 kc.

OUTPUT RATING

Maximum 9.0 Watts
Undistorted 6.0 Watts

LOUDSPEAKER

Type Electrodynamic
Impedance (v. c.) 3 Ohms at 400 Cycles

POWER RATING

Supply Voltage 6.3 Volts (Storage Battery)
Current Drain 7.3 Amperes at 6.3 Volts
Fuse Protection 15 Amperes
Pilot Lamp Mazda No. 44, 6.3 Volts

ALIGNMENT FREQUENCIES

I. F. Transformers 260 kc.	Detector Coil 1,400 kc.
Oscillator Coil 600 kc. and 1,400 kc.	Antenna Coil 1,400 kc.

Mechanical Specifications

RECEIVER CASE DIMENSIONS

	Model 6M	Model 6M2
Height	7 Inches	7 Inches
Width	10 $\frac{1}{8}$ Inches	10 $\frac{1}{8}$ Inches
Depth	7 $\frac{1}{8}$ Inches	7 $\frac{1}{8}$ Inches

LOUDSPEAKER CASE DIMENSIONS Model 6M2

Diameter 8 $\frac{3}{4}$ Inches Depth 5 Inches

OPERATING CONTROLS (1) Power Switch-Volume, (2) Tuning, (3) High-Frequency Tone

TUNING DRIVE RATIO 12-to-1

WEIGHT

	Model 6M	Model 6M2
Receiver and Accessories Complete	24 $\frac{1}{4}$ Pounds	29 Pounds
Complete Equipment Packed for Shipment	26 $\frac{3}{4}$ Pounds	32 $\frac{1}{2}$ Pounds

General Description

These two automobile receivers represent the results of thorough development, design, and substantial manufacture. Noteworthy technical improvements have been applied in achieving marked advantages of installation, operation, and efficiency of performance.

Model 6M is a single-unit receiver containing the radio chassis, power conversion system, and loudspeaker all in one housing. A convenient three-contact loudspeaker receptacle installed on the chassis case permits the addition of a remote dynamic loudspeaker if desired.

Model 6M2 is a double-unit receiver utilizing a

chassis and its power conversion equipment similar to the Model 6M, assembled together in one case, with its loudspeaker mounted individually in a separate cylindrical housing.

Engineering features incorporated in these instruments are: The inclusion of ignition suppression means within the circuits of the receiver; reduction of power line modulation in antenna circuit; improved high-gain molded core antenna coil; permeability tuned intermediate frequency transformers; continuously variable high-frequency tone control; and a "plug-in" type of synchronous rectifier-vibrator for obtaining high-voltage supply.

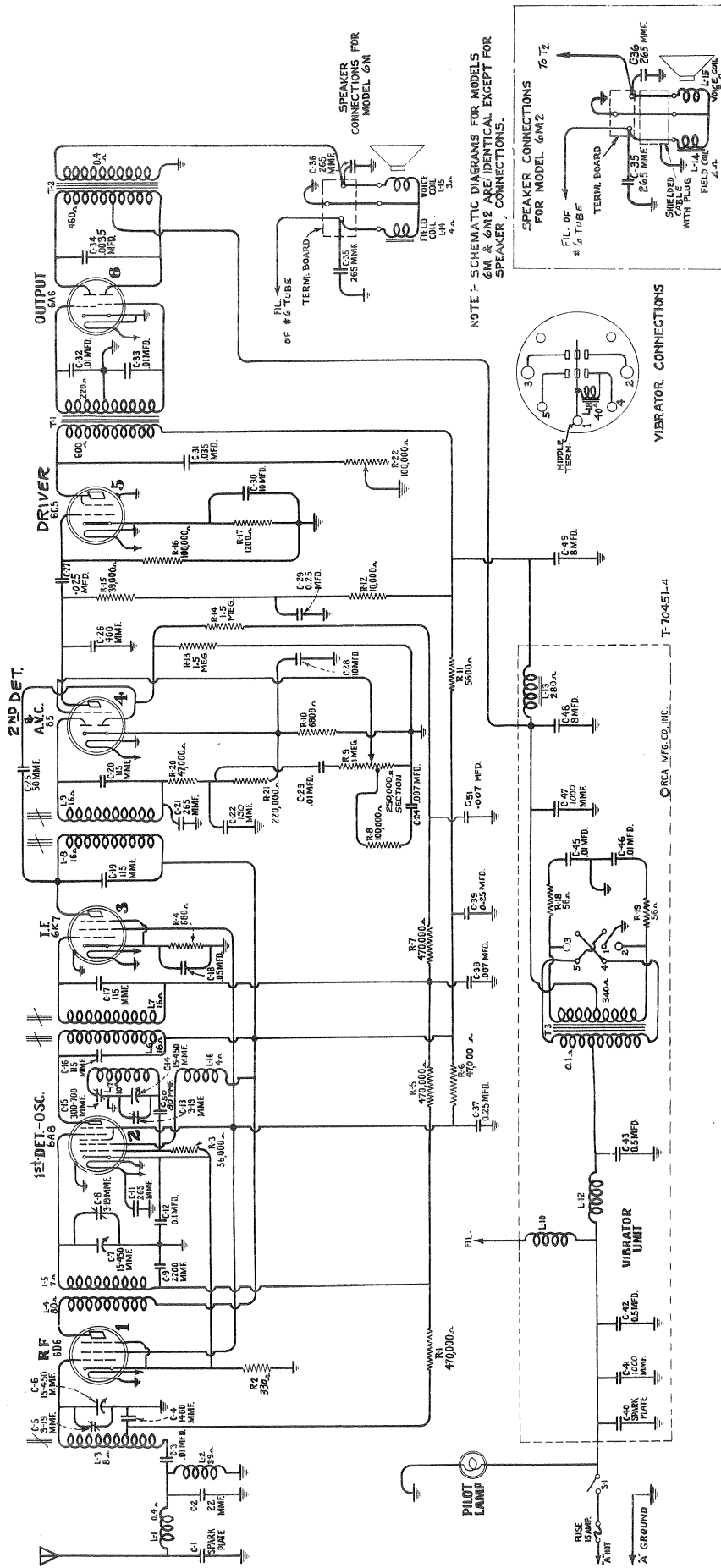

NOTE - SCHEMATIC DIAGRAMS FOR MODELS 6N1 & 6N2 ARE IDENTICAL EXCEPT FOR SPEAKER CONNECTIONS.

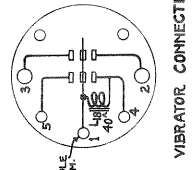
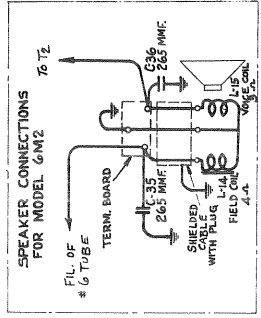

Figure 1—Schematic Circuit Diagram
 Certain automobile installations require change of value of capacitor C-3. See note in text under "Service Data."

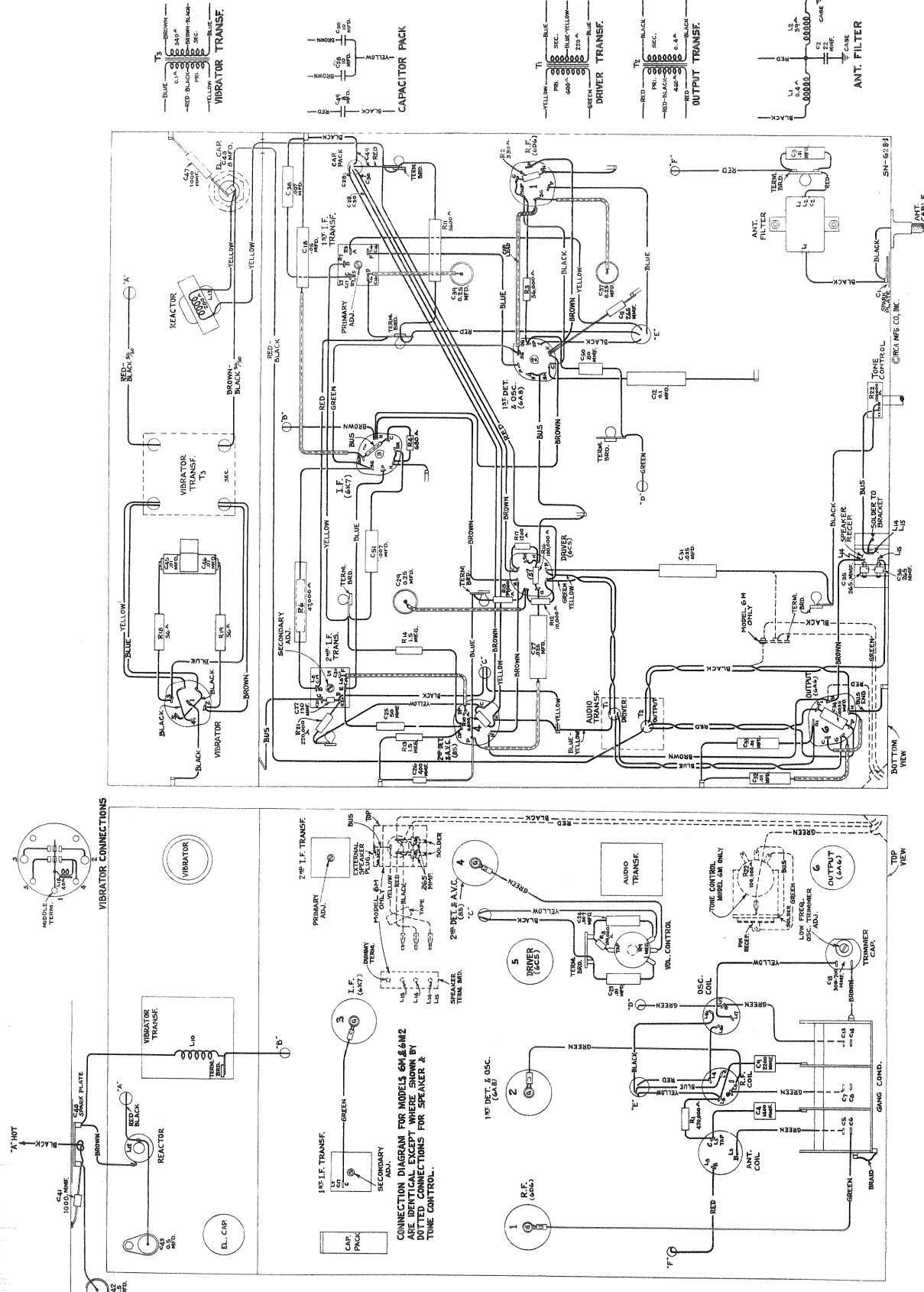

Figure 2—Chassis Wiring Diagram

Correct arrangement of parts, adequate shielding, and the ingenious insertion of filters at proper points in the circuit insure minimum disturbances from apparatus associated with the electrical circuits of the automobile and from outside sources.

Both receivers are compactly housed in substantial

Circuit Arrangement

The schematic and wiring layouts of the electrical circuit are shown in Figures 1 and 2 respectively. From these diagrams it may be seen that six Radiotrons are incorporated in the basic superheterodyne circuit. In sequence, there is an r-f stage, a dual first detector-oscillator stage, a single i-f stage, a second detector-audio amplifier-a.v.c. stage, a driver stage, and a class "B" output stage. The power supply system contains a mechanical interrupter and rectifier. The following circuit features are of particular importance:

Noise Filter—Reduction of ignition interference and similar disturbances are brought about by filter arrangements in the antenna input circuit and the "A" battery input lead. This antenna filter, L-1, C-1,

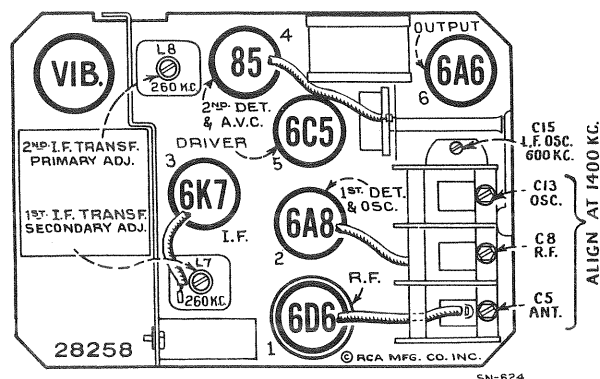

Figure 3—Radiotron, Coil, and Trimmer Locations

and C-2, is a "low-pass" type, having an acceptance band below 1,600 kc. The inductance L-2 is for the purpose of shunting out power line hum pickup.

Tuned Circuits—There are seven resonant circuits in the radio frequency end of the receiver. The r-f, first detector, and oscillator grid circuits are tuned by a three-gang tuning condenser. The remaining

metal cases. Removable covers permit ready access to the under and top sides of the chassis. Flexible shafts interconnect the operating head to the controlled devices within the receiver housing. These units are adaptable for mounting on either the right-hand or the left-hand side of the engine firewall as local conditions demand.

tuned circuits consist of the primary and secondary windings of the i-f transformers, which resonate with fixed condensers and are tuned by molded cores to a nominal frequency of 260 kilocycles.

Detection—Detection takes place as a result of the rectifying action of one of the diodes of the RCA-85 tube, the current being developed through resistors R-20 and R-21. The audio component of this current is coupled through capacitor C-23 to the one megohm volume control R-9. The arm of this volume control is connected to the grid of the RCA-85 tube, thus giving a means of continuously varying the voltage input to the audio amplifier.

A.V.C.—The a.v.c. diode of the RCA-85 tube is coupled through capacitor C-25 to the primary of the second i-f transformer. Due to the rectifying action of this diode, a current is developed through resistor R-13. The d-c voltage drop in this resistor is used for automatically regulating the control grid bias of the r-f, first detector, and i-f stages, the voltage being applied through a suitable filter network. Due to the fact that the a.v.c. diode returns through resistor R-13 to a point which is 15 volts negative with respect to its cathode, the a.v.c. action is delayed until the input signal reaches a predetermined level. This gives more uniform output for widely varying signal strengths into the antenna.

Audio System—As mentioned under "Detection", the audio component of the detected signal is selected from the manual volume control and applied to the control grid of the RCA-85 tube. The plate circuit of this tube is connected through capacitor C-27 to the control grid of the driver tube, an RCA-6C5. The plate circuit of the driver tube is coupled through the driver transformer T-1 to the control grids of the class "B" output tube, RCA-6A6. This tube is coupled through the output transformer T-2 to the loudspeaker.

SERVICE DATA

Alignment Procedure

There are four alignment trimmers provided in the antenna coil, detector coil, and oscillator coil tuned circuits. The i-f transformer adjustments are made by means of four screws attached to molded cores.

NOTE: The antenna coil has a molded core which is adjusted at the factory for the correct inductance. This adjustment should not be disturbed.

In readjusting the tuned circuits, it is important to apply a definite procedure and to use adequate and reliable test equipment. A standard test oscillator,

NOTE: Certain models of 1936 automobiles are equipped with "high-capacitance type" (400 mmfd. or greater) built-in antennas. The 1936 models of Dodge, De Soto, and Chrysler are examples of automobiles so equipped. Installation of receiver in automobiles with such "high-capacity" antennas necessitates the following modification of the antenna circuit of the receiver to suit the characteristics of the antenna installation:

Remove the tubular paper-covered capacitor C-3 (.01 mfd.), Figure 2, and replace with the small molded type capacitor (500 mmfd.) furnished with Escutcheon Kit for respective model of automobile.

such as the RCA Stock No. 9595, will be required as the source of signal at the specified alignment frequencies. Means for indication of the receiver output during alignment is also necessary to accurately shown when the correct point of adjustment is reached. Two indication methods are applicable—one requires use of the cathode-ray oscillograph, and the other requires a voltmeter or glow-type indicator. The cathode-ray alignment method is advantageous in that the indication provided is in the form of a wave image which represents the resonance characteristics of the circuits being tuned. This type of alignment is possible through use of apparatus such as the RCA Stock No. 9558 Frequency Modulator and the RCA Stock No. 9545 Cathode-Ray Oscillograph. Alignment by the output meter method should be indicated by an instrument such as the RCA Stock No. 4317 Neon Glow Indicator. The two procedures are outlined as follows:

CATHODE-RAY ALIGNMENT

Attach the cathode-ray oscillograph vertical input terminals to the second detector output, with the "Hi" connected to the junction of the two resistors, R-20 and R-21, and the "0" connected to the receiver chassis. Advance the vertical amplifier gain control of the oscillograph to full-on, allowing it to remain at such position for all adjustments. Turn the vertical "A" amplifier to "On." Set the oscillograph power switch to "On" and adjust the intensity and focusing controls to give a sharply defined spot on the screen. Interconnect the frequency modulator impulse generator terminals to the oscillograph "Ext. Sync." terminals, as shown by Figure 4.

I-F Adjustments

- (a) Connect the output of the test oscillator to the control grid cap of the i-f tube (RCA-6K7) through a 0.25 mfd. capacitor and connect the ground of the oscillator to the receiver chassis. Tune the oscillator to 260 kc., place its modulation switch to "On" and its output range switch to "Hi." The frequency modulator must not be connected to the oscillator for the preliminary adjustments.
- (b) Set the cathode-ray oscillograph horizontal "B" amplifier to "Timing" and the synchronizing switch (timing) to "Int." Place the synchronizing input and frequency controls to about their mid-positions. Turn the range switch to its No. 1 position.
- (c) Increase the output of the oscillator until a deflection is noticeable on the oscillograph screen. The figure obtained represents several waves of the detected signal, the amplitude of which may be observed as an indication of output. Cause the wave image formed (400-cycle waves) to be spread completely across the screen by advancing the horizontal "B" gain control. The image should be synchronized and made to remain motionless by adjustment of the synchronizing input and frequency controls.
- (d) Adjust the two screws (attached to molded

cores) of the second i-f transformer, one on top and one on bottom, to produce maximum vertical deflection of the oscillographic wave which is present on the screen. This adjustment places the transformer in exact resonance with the 260 kc. signal.

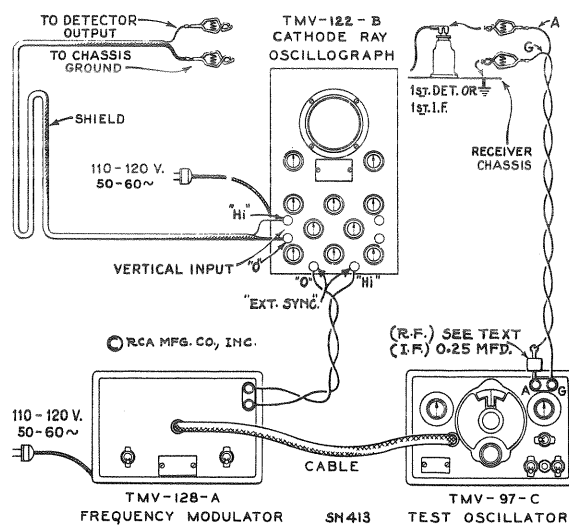

Figure 4—Alignment Apparatus Connections

- (e) The sweeping operation should follow using the frequency modulator. Shift the oscillograph synchronizing switch to "Ext.," change its range switch to No. 2 position and set the frequency control to its mid-position. Place the frequency modulator in operation, with its sweep range switch in the "Lo" position. Interconnect the test oscillator and frequency modulator with the special shielded patch cord provided. Turn the oscillator modulation switch to "Off."
- (f) Increase the frequency of the test oscillator by slowly turning its tuning control until two separate, distinct, and similar waves appear on the screen. These waves will be identical in shape, but will be totally disconnected and appearing in reversed positions. They will have a common base line, which is discontinuous. Adjust the frequency and synchronizing input controls of the oscillograph to get the proper waves and to make them remain motionless on the screen. Continue increasing the oscillator frequency until the forward and reverse curves move together and overlap, with their highest points exactly coincident. This condition will obtain at an oscillator setting of approximately 360 kc.
- (g) With the images established as in (f), readjust the two screws on the second i-f transformer so that they cause the curves on the oscillograph screen to become exactly coincident throughout their lengths and have maximum amplitude.
- (h) Without altering the adjustments of the apparatus, shift the output connections of the oscillator to the input of the i-f system, i. e., be-

tween the first detector (RCA-6A8) control grid and ground. Regulate its output so that the amplitude of the oscillographic image is approximately the same as used above for adjustment (g) of the second i-f transformer.

- (i) The two first i-f transformer adjustment screws, one on top and one on bottom, should then be adjusted so that they cause the forward and reverse curves to become coincident throughout their lengths and have maximum amplitude. The composite wave obtained in this manner represents the resonance characteristic of the total i-f system. Lack of symmetry or irregularity of the resultant image will indicate the presence of a defect in the i-f system.

R-F Adjustments

NOTE: Before making r-f adjustments, it may be advisable to replace the bottom cover to eliminate vibrator interference.

- (a) Adjust the dial pointer on the remote control head by the following procedure. Rotate tuning knob to its extreme clockwise position irrespective of location of pointer on dial. Now turn the pointer adjusting screw in the center of the back of the control unit until the pointer is at the end calibration mark below the 55 on dial scale.
- (b) Attach the output of the test oscillator to the receiver input, i. e., between the antenna and ground terminals, with a 175 mmfd. capacitor in series with antenna lead.

NOTE: For r-f alignment of receivers in which the tubular paper condenser C-3 (.01 mfd.) has been replaced by the small molded condenser 500 mmfd. (change easily identified by reference to Figure 2 and bottom of chassis), use a .001 mfd. capacitor instead of the 175 mmfd. capacitor in series with the antenna lead and test oscillator.

There should be a shunt capacitor of 50 or 60 mmfd. from the antenna lead at the receiver to ground. Accurately tune the oscillator to 1,400 kc. The oscillograph should be left connected to the second detector output circuit as for the above i-f adjustments. Return the synchronizing switch to its "Int." position and turn the range switch to its No. 1 position.

- (c) Tune the receiver to a dial reading of 1,400 kc. Then regulate the oscillator output so as to increase the amplitude of the waves on the oscillograph screen to a conveniently observable size. The several waves of detected signal, as appearing on the screen, should be synchronized by operation of the synchronizing and frequency controls. Trimmers, C-13, C-8, and C-5, of the oscillator, detector, and antenna coils should then be adjusted so that each causes maximum vertical deflection (amplitude) of the images.

- (d) The oscillator modulation should then be turned to "Off" and the frequency modulator placed in operation, connected to the oscillator with the shielded patch cord. Change the oscillograph synchronizing switch to "Ext.", set its range switch to its No. 2 position and the frequency control slightly above its mid-position.

- (e) Increase the frequency of the test oscillator gradually, until the point is reached where the two similar, distinct, and separate wave images appear on the screen and become coincident at their highest points. This will occur at an oscillator setting of approximately 1,500 kc. These waves should be synchronized on the oscillograph screen by careful readjustment of the synchronizing and frequency controls. Re-adjust trimmers, C-13, C-8, and C-5, to produce complete coincidence at maximum amplitude of the two waves.

- (f) Disconnect the frequency modulator from the oscillator. Place the modulation switch of the oscillator to "On" and tune the oscillator to 600 kc. Set the synchronizing switch of the oscillograph to "Int." and turn the range switch to No. 1 position.

- (g) Tune the receiver station selector control so as to pick up the 600 kc. signal, disregarding the dial reading at which it is best received.

- (h) Change the oscillograph synchronizing switch to "Ext." and place the oscillator modulation switch to "Off." Interconnect the frequency modulator and oscillator with the special shielded patch cord. Return the range control of the oscillograph to its No. 2 position and set the frequency control slightly above its mid-position.

- (i) Shift the test oscillator to its 200-400 kc. range and tune it to the point at which the forward and reverse waves show on the oscillograph screen. This condition will obtain at an oscillator setting of approximately 230 kc. The signal obtained from the oscillator for this adjustment will be the third harmonic of 200 kc. An increase in the oscillator output may be necessary. The trimmer C-15 should then be adjusted to the point which produces maximum amplitude of the oscillographic images. It will not be necessary to rock the tuning control for this adjustment, inasmuch as the frequency modulator is varying the signal in an equivalent manner.

- (j) Retune trimmers C-13, C-8, and C-5 as in (c), (d), and (e) to correct for any change in high-frequency alignment which may have been caused by the adjustment of C-15.

OUTPUT METER ALIGNMENT

Place the receiver in operation with its two covers removed. Attach the output indicator across the loudspeaker voice coil circuit or across the output transformer primary. Advance the receiver volume

control to its maximum position, letting it remain in such position for all adjustments. For each adjusting operation, regulate the test oscillator output so that the signal level is as low as possible and still observable at the receiver output. Use of such small signal will obviate broadness of tuning which would otherwise result from a.v.c. action on a stronger one.

I-F Adjustments

- (a) Connect the output of the test oscillator to the control grid cap of the i-f tube (RCA-6K7) through a 0.25 mfd. capacitor and connect the ground of the oscillator to the receiver chassis. Adjust the frequency of the oscillator to 260 kc. Tune the receiver to a point where no interference is received from the heterodyne oscillator or local stations.
- (b) Adjust the two screws (attached to molded cores) of the second i-f transformer, one on top and one on bottom, until maximum output is produced by the indicating device.
- (c) Remove the oscillator from the i-f tube input and connect it between the control grid cap of the first detector tube (RCA-6A8) and chassis-ground, using the 0.25 mfd. capacitor as previously. Allow its tuning to remain at 260 kc. Tune the receiver to avoid interference as in (a).
- (d) Adjust the two screws of the first i-f transformer for maximum (peak) receiver output. The indication for this adjustment will be broad due to the "flat-top" characteristic of the i-f system. The two screws should, therefore, be very carefully adjusted so that the indicator remains fixed at maximum as the oscillator is shifted through a range 2 kc. above and below its normal setting of 260 kc. An irregular double-peaked indication is to be avoided.

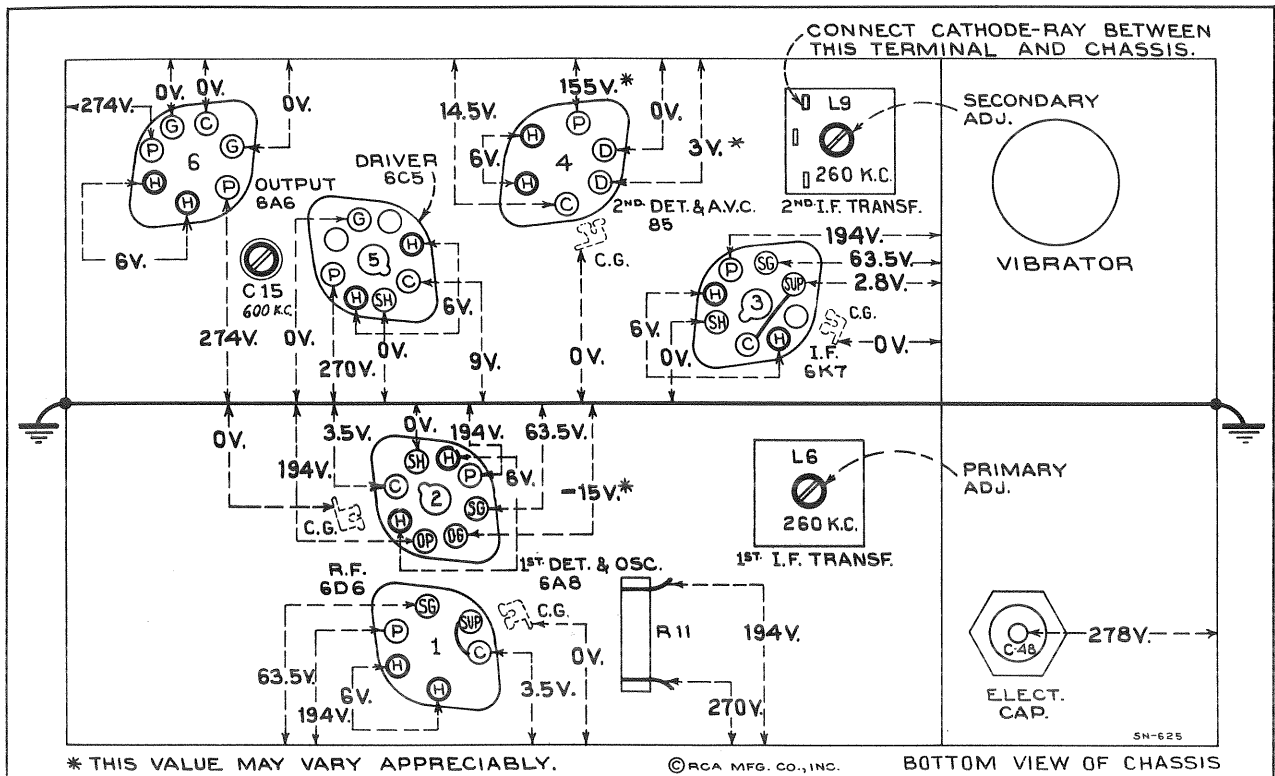

Figure 5—Radiotron Socket Voltages and Trimmer Locations
(Measured at 6.3 volts battery supply—Volume Control Maximum—No Signal)

Radiotron Socket Voltages

Operating conditions of the basic circuits of this instrument may be determined by measuring the voltages applied to the tube elements. Figure 5 shows the voltage values from the socket contacts to ground and appearing across the heater contacts (H-H). Each value as specified should hold within $\pm 20\%$ when this instrument is normally operative with all tubes intact and rated voltage applied. Variations in excess of this limit will usually be indicative of trouble.

The voltages given on this diagram are actual measured voltages, and are obtained with the voltmeter load in the circuit.

To fulfill the conditions under which the d-c voltages were measured requires a 1,000-ohm-per-volt d-c voltmeter having ranges of 10, 50, 250, and 500 volts. Voltages below 10 volts should be measured on the 10-volt scale; between 10 and 50 on the 50-volt scale; between 50 and 250 on the 250-volt scale; and above 250 on the 500-volt scale.

R-F Adjustments

NOTE: Before making r-f adjustments, it may be advisable to replace the bottom cover to eliminate vibrator interference.

- (a) Adjust the dial pointer on the remote control head by the following procedure. Rotate tuning knob to its extreme clockwise position irrespective of location of pointer on dial. Now turn the pointer adjusting screw in the center of the back of the control unit until the pointer is at the end calibration mark below the 55 on dial scale.
- (b) Connect the output of the test oscillator to the antenna-ground terminals of the receiver with a 175 mmfd. capacitor in series with the antenna lead.

NOTE: For r-f alignment of receivers in which the tubular paper condenser C-3 (.01 mfd.) has been replaced by the small molded condenser 500 mmfd. (change easily identified by reference to Figure 2 and bottom of chassis), use a .001 mfd. capacitor instead of the 175 mmfd. capacitor in series with the antenna lead and test oscillator.

There should be a shunt capacitor of 50 or 60 mmfd. from the antenna lead at the receiver to ground. Tune the oscillator to 1,400 kc. Al-

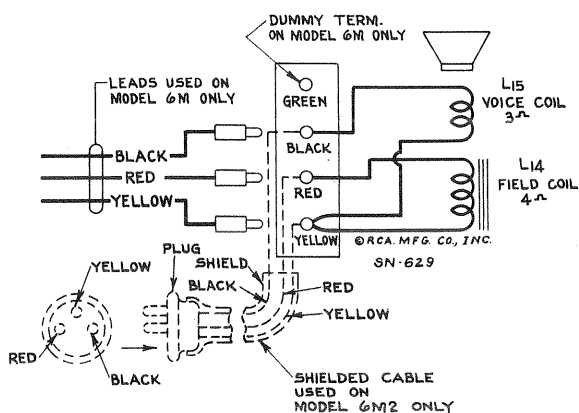

Figure 6—Loudspeaker Schematic and Wiring

low the output indicator to remain attached to the receiver output.

- (c) Tune the receiver so that the dial reading is 1,400 kc. Then adjust the oscillator, detector, and antenna coil trimmers, C-13, C-8, and C-5 respectively, tuning each to the point producing maximum indicated receiver output.
- (d) Shift the oscillator frequency to 600 kc. and tune the receiver to pick up this signal, disregarding the dial reading at which it is best received. The oscillator series trimmer, C-15, should then be adjusted, simultaneously rocking the receiver tuning control backward and forward through the signal until maximum (peak) receiver output results from the combined operations. The adjustment of C-13, C-8 and C-5 should be repeated as in (c) to

correct for any change in its alignment due to the adjustment of C-15.

Final Tuning Dial Adjustment

Final adjustment of the dial pointer may be made during operation after the receiver is installed in automobile. To do this, tune in a station of known frequency (say 760 kc.—approximately 76 on dial) as accurately as possible. Now reset the dial pointer to exactly 76 on the dial by means of the adjusting screw at center rear of operating head.

Volume Control and Power Switch

This adjustment is made by turning the small control knob fully clockwise and then fully counterclockwise. This places the friction clutch mechanism on the volume control in proper alignment.

Tuning Condenser Drive

Smooth control should be obtained over the entire tuning range of the variable condenser. If irregularity is present, check the action of the gear mechanism for binding or backlash at every point within the tuning range. A bind may be due to improper mesh between the worm gear and the large gears on the condenser shaft. To correct such a condition, loosen the three screws holding the gear plate and adjust the mesh of the gears to a position which gives smooth operation. Gear backlash is prevented by the small compression spring between the two large gears on the rotor shaft.

Interrupter

The mechanical interrupter used in the power system is constructed with a plug-in base, so as to be easily removed from the receiver. Its adjustments have been correctly set during manufacture by means of special equipment. In cases of faulty operation of the interrupter, a renewal should be made.

The symmetrical plug-in base on this device permits the unit to be placed in its socket so as to give correct output voltage polarity on an automobile with either a positive or negative "A" ground. For installation with positive "A" ground, insert vibrator so positive (+) symbol is nearest label on vibrator compartment partition; for negative "A" ground, insert with negative (-) symbol nearest label.

Radiotrons

Deterioration of tubes and their approach to failure is usually evidenced by noisy or intermittent operation, loss of sensitivity, and distorted tone quality. When suspected as faulty, the tubes should be removed from the receiver and checked with standard tube testing apparatus. It is not feasible to test the tubes while in the receiver, due to measurement inaccuracies which would result from the effects of the circuits.

Receiver Housing

The screws holding the receiver chassis to the case must all be in place and tightly installed, inasmuch as they appreciably affect the ground resistance of the assembly and will consequently have a bearing on the amount of ignition noise received.

REPLACEMENT PARTS

Insist on genuine factory tested parts, which are readily identified and may be purchased from authorized dealers

Stock No.	DESCRIPTION	List Price	Stock No.	DESCRIPTION	List Price
RECEIVER ASSEMBLIES					
12511	Cap—Grid contact cap—Package of 5	\$0.15	12266	Resistor—39,000 ohm—insulated, ¼ watt —(R15)—Package of 5	\$1.00
11130	Capacitor—Adjustable capacitor—(C15)	.40	5132	Resistor—47,000 ohm—carbon type, 1/10 watt—(R20)—Package of 5	.75
11289	Capacitor—50 Mmfd.—(C25)	.26	12073	Resistor—47,000 ohm—carbon type, 1 watt—(R6)—Package of 5	1.10
12270	Capacitor—80 Mmfd.—(C50)	.28	12286	Resistor—56,000 ohm—insulated, ¼ watt —(R3)—Package of 5	1.00
11998	Capacitor—115 Mmfd.—(C16, C17, C19, C20)	.28	12263	Resistor—100,000 ohm—insulated, ¼ watt —(R16)—Package of 5	1.00
12725	Capacitor—150 Mmfd.—(C22)	.28	11281	Resistor—100,000 ohm—carbon type, 1/10 watt—(R8)—Package of 5	.75
11181	Capacitor—265 Mmfd.—(C11, C35, C36)	.20	12264	Resistor—220,000 ohm—insulated, ¼ watt—(R21)—Package of 5	1.00
12761	Capacitor—265 Mmfd.—(C21)	.15	11452	Resistor—470,000 ohm—carbon type, 1/10 watt—(R5, R7)—Package of 5	.75
11171	Capacitor—400 Mmfd.—(C26)	.22	12285	Resistor—470,000 ohm—insulated, ¼ watt—(R1)—Package of 5	1.00
12762	Capacitor—1,000 Mmfd.—(C41, C47)	.20	12287	Resistor—1.5 megohm—insulated, ¼ watt—(R13, R14)—Package of 5	1.00
12268	Capacitor—1,400 Mmfd.—(C4)	.34	3584	Ring—Retaining ring for R. F. or oscillator coil—Package of 5	.40
12269	Capacitor—2,200 Mmfd.—(C9)	.42	5129	Ring—Radiotron shield ring—Package of 5	.10
5005	Capacitor—.0035 Mfd.—(C34)	.16	3623	Shield—R. F. or oscillator coil shield	.30
5148	Capacitor—.007 Mfd.—(C24, C38, C51)	.20	12290	Shield—Radiotron shield	.18
4858	Capacitor—.01 Mfd.—(C3, C23, C32, C33)	.25	4786	Socket—6-contact 6D6 or 85 Radiotron socket	.15
4870	Capacitor—.025 Mfd.—(C27)	.20	12243	Socket—7-contact 6A6 Radiotron socket	.18
5196	Capacitor—.035 Mfd.—(C31)	.18	12227	Socket—8-contact 6A8, 6C5 or 6K7 Radiotron socket	.18
4836	Capacitor—.05 Mfd.—(C18)	.30	12241	Socket—Vibrator socket	.18
4841	Capacitor—.1 Mfd.—(C12)	.22	12226	Stud—Variable tuning condenser mounting stud assembly—Package of 4	.22
12237	Capacitor—.25 Mfd.—(C29, C37, C39)	1.02	12228	Transformer—First I. F.—(L6, L7, C16, C17, R5, R7)	2.24
5019	Capacitor—.5 Mfd.—(C43)	.42	12230	Transformer—Output transformer—(T1, T2)	2.95
12234	Capacitor—8 Mfd.—(C48)	1.34	12229	Transformer—Second I. F. transformer —(L8, L9, C19, C20, C21, R20)	2.02
12233	Capacitor Pack—Comprising 2 sections each .01 Mfd.—(C45, C46)	1.02	12231	Transformer—Vibrator power transformer—(T3)	3.42
12238	Capacitor Pack—Comprising one 8 Mfd. and two 10 Mfd. sections—(C28, C30, C49)	2.30	12236	Vibrator complete	4.55
12223	Coil—Antenna coil—(L3)	.94	12240	Volume Control—(R9)	1.14
12235	Coil—Choke coil—(L12)	.50	CONTROL BOX AND FLEXIBLE SHAFT ASSEMBLIES		
12225	Coil—Oscillator coil—(L16, L17)	.80	12505	Box—Control box complete—less flexible shafts	6.35
12224	Coil—R. F. coil—(L4, L5)	1.32	12578	Dial—Station selector indicator dial (standard)	.50
12220	Condenser—3-gang variable tuning condenser—(C5, C 6, C7, C8, C13, C14)	4.50	12579	Knob—Station selector (tuning) knob (standard)	.28
12006	Core—Adjustable core for I. F. transformer Stock No. 12228 and No. 12229	.22	12580	Knob—Volume control knob (standard)	.28
12289	Coupling—Station selector flexible shaft coupling	.20	11891	Lamp—Control box dial lamp—Package of 5	.65
12239	Filter—Antenna filter—(L1, L2, C2)	1.28	12504	Shaft—Tuning control flexible shaft complete—approx. 21½ in. long	1.20
12221	Gear—Variable tuning condenser shaft drive gear (without tapped shaft)	.36	12503	Shaft—Volume control flexible shaft complete—approx. 21½ in. long	1.20
12222	Gear—Variable tuning condenser worm gear (use with No. 12221 only)	.36	REPRODUCER ASSEMBLIES, MODEL 6M		
12242	Guide—Station selector shaft guide	.18	12482	Board—Reproducer terminal board	.30
12483	Pin—Contact pin for speaker leads (used in 6M only)—Package of 5	.15	12450	Coil—Field coil—(L14)	1.60
12485	Pin—Contact pin for tone control lead (used in 6M only)—Package of 5	.15	12451	Cone—Reproducer cone complete—(L15)	1.60
12232	Reactor—Filter reactor—iron core—(L13)	1.10	9687	Reproducer—Reproducer complete	5.65
5034	Resistor—56 ohm—carbon type, ½ watt —(R18, R19)—Package of 5	1.00			
12481	Resistor—330 ohm—insulated, ¼ watt—(R2)—Package of 5	1.00			
12262	Resistor—680 ohm—insulated, ¼ watt—(R4)—Package of 5	1.00			
12267	Resistor—1,200 ohm—insulated, ¼ watt —(R17)—Package of 5	1.00			
8097	Resistor—5,600 ohm—carbon type, 2 watt —(R11)	.25			
12265	Resistor—6,800 ohm—insulated, ¼ watt —(R10)—Package of 5	1.00			
12288	Resistor—10,000 ohm—insulated, ¼ watt —(R12)—Package of 5	1.00			

The prices quoted above are subject to change without notice.

REPLACEMENT PARTS (Continued)

Stock No.	DESCRIPTION	List Price	Stock No.	DESCRIPTION	List Price
	REPRODUCER ASSEMBLIES, MODEL 6M2		12623	Grille—Speaker grille assembly (used on 6M only)	\$0.88
12526	Board—2-contact reproducer terminal board	\$0.20	12456	Housing—Receiver housing complete (used on 6M only)	4.60
12525	Cable—Shielded reproducer cable complete with 3-contact male connector	1.08	12460	Housing—Receiver case complete (used on 6M2 only)	4.58
12524	Coil—Field coil—(L14)	1.85	4290	Insulator—Fuse connector insulator—Package of 10	.35
12523	Cone—Reproducer cone—(L15)	1.65	4323	Knob—Tone control knob (used on 6M only)—Package of 5	.70
12527	Housing—Reproducer housing complete	2.65	4132	Knob—Tone control knob (used on 6M2 only)—Package of 5	.55
9691	Reproducer—Reproducer complete	11.38	12445	Lead—"A" lead (set end), approx. 8 in. long, complete with male section of connector	.26
12528	Screw—Reproducer housing screw—Package of 5	.14	12506	Plate—Name plate and mounting screws (used in 6M only)	.28
	MISCELLANEOUS ASSEMBLIES		12507	Plate—Name plate and mounting screws (used in 6M2 only)	.28
4287	Body—Antenna cable female connector body—Package of 10	.40	12508	Plate—RCA monogram and rivets (used on 6M2 only)	.28
4289	Body—"A" lead fuse connector body—Package of 10	.35	12609	Ring—Rubber ring for speaker mounting (used on 6M2 only)	.28
12510	Button—Plug button for receiver housing (used on 6M only)	.16	12459	Screw—Speaker mounting screw assembly, consisting of 1 screw, 1 nut, and 1 lockwasher to mount speaker in case (used on 6M only)—Package of 4	.20
12444	Cable—Shielded antenna cable approx. 8 in. long, complete with female-section of connector	.58	12533	Screw—Self-tapping slotted hex. head, 1/4 in. long, used in receiver housing—Package of 10	.16
12473	Cable—Shielded antenna lead-in cable, approx. 31 in. long, complete with 2 male connections of connector	1.12	4393	Screw—Set screw for tone control knob Stock No. 4132 (used on 6M2 only)—Package of 10	.25
4288	Cap—Male connector cap for "A" lead or antenna cable—Package of 10	.36	12248	Socket—3-contact socket and bracket assembly for reproducer cable	.20
5025	Capacitor—Generator capacitor	.40	12502	Socket—Pin socket and bracket assembly for tone control lead	.30
4293	Capacitor—Ammeter capacitor	.60	4284	Spring—Antenna cable connector spring—Package of 10	.30
11418	Capacitor—.5 Mfd.—(C42)	.50	12448	Stud—Receiver mounting stud assembly, comprising 1 stud, 1 washer, 1 lockwasher and 1 nut	.20
4291	Clip—"A" lead ammeter clip—Package of 10	.70	12254	Stud—Speaker mounting stud assembly, comprising 1 stud, 1 spacer, 1 washer and 2 nuts (used in 6M2 only)	.24
12457	Cover—Receiver housing top cover (used on 6M only)	.65	5024	Suppressor—Distributor suppressor	.38
12458	Cover—Receiver housing bottom cover assembly (used on 6M only)	.60	12249	Tone Control—(R22)	.88
12461	Cover—Receiver case bottom cover (used in 6M2 only)	.60	4285	Washer—Antenna cable connector insulating washer—Package of 10	.22
12462	Cover—Receiver case top cover (used in 6M2 only)	.62			
12532	Fastener—Receiver housing top cover fastener—Package of 10	.30			
4286	Ferrule—Antenna cable or "A" lead connector ferrule and bushing—Package of 10	.38			
5023	Fuse—"A" lead fuse—15 amp.—Package of 5	.40			

The prices quoted above are subject to change without notice.