

RCA VICTOR MODEL 7U

Seven-Tube, Three-Band, A-C, Radio—Phonograph

TECHNICAL INFORMATION

Electrical Specifications

FREQUENCY RANGES

"Standard broadcast" (A) 540-1,625 kc.
 "Medium wave" (B) 1,625-5,700 kc.
 "Short wave" (C) 5,700-18,000 kc.

Intermediate Frequency 460 kc.

RADIOTRON COMPLEMENT

(1) RCA-6A8 First-detector-oscillator
 (2) RCA-6K7 Intermediate amplifier
 (3) RCA-6H6 Second-detector-a.v.c.

Pilot Lamps (5) Mazda No. 46, 6.3 volts, 0.25 amperes

POWER SUPPLY RATINGS

Rating A-6 105-125 volts, 60 cycles, 95 watts
 Rating A-5 105-125 volts, 50 cycles, 95 watts
 Rating B-2 105-125 volts, 25 cycles, 95 watts
 Rating C-6 105-130/140-160/200-250 volts, 60 cycles, 95 watts
 Rating C-5 105-130/140-160/200-250 volts, 50 cycles, 95 watts

POWER OUTPUT

Undistorted 2.0 watts
 Maximum 4.5 watts

PHONOGRAPH

Type Manual
 Turntable Speed 78 r.p.m.

ALIGNMENT FREQUENCIES

"Standard broadcast" (A) ... 600 kc. (osc.), 1,400 kc. (osc. and ant.)

"Medium wave" (B) None required

"Short wave" (C) 15,000 kc. (osc. and ant.)

..... 460 kc.

(4) RCA-6F5 Audio voltage amplifier

(5) RCA-6F6 Audio power amplifier

(6) RCA-5Z4 Full-wave rectifier

(7) RCA-6E5 Tuning tube

..... Mazda No. 46, 6.3 volts, 0.25 amperes

LOUDSPEAKER

Type Electrodynamic
 Impedance (v.c.) 2.2 ohms at 400 cycles

Type of Pickup High-impedance magnetic

Pickup Impedance 1,400 ohms at 1,000 cycles

Mechanical Specifications

Height 40 $\frac{3}{16}$ inches
 Width 23 $\frac{9}{16}$ inches
 Depth 14 $\frac{3}{8}$ inches
 Weight (net) 71 pounds
 Weight (shipping) 91 pounds
 Chassis Base Dimensions 12 inches x 7 inches x 2 $\frac{1}{2}$ inches
 Over-all Chassis Height 8 inches
 Operating Controls. (1) Power switch-Tone, (2) Tuning, (3) Volume, (4) Range selector, (5) Radio-Phono-volume
 Tuning Drive Ratios 10 to 1 and 50 to 1

General Features

The Model 7U combination instrument consists of a seven-tube radio receiver and a manually-operated phonograph combined in one cabinet. The super-heterodyne circuit is used with such features of design as: Antenna wave-trap, aural compensated volume control, continuously variable tone control with music-voice switch, automatic volume control, resistance-coupled audio system, tuning tube "Magic Eye,"

and band selective indication of dial scales. The tuning range is continuous through the "Standard broadcast" band, "Medium wave" band, and the "Short wave" band. It includes domestic broadcast, police, aircraft, and amateur services, and also the important foreign short-wave broadcast bands at 49, 31, 25, 19, and 16 meters.

Circuit Arrangement

The first detector and oscillator functions are accomplished in a single tube, an RCA-6A8. The input of this tube is coupled to the antenna through a tuned

transformer. This transformer consists of a single primary and three series-connected secondary windings to provide the three ranges of tuning. The oscil-

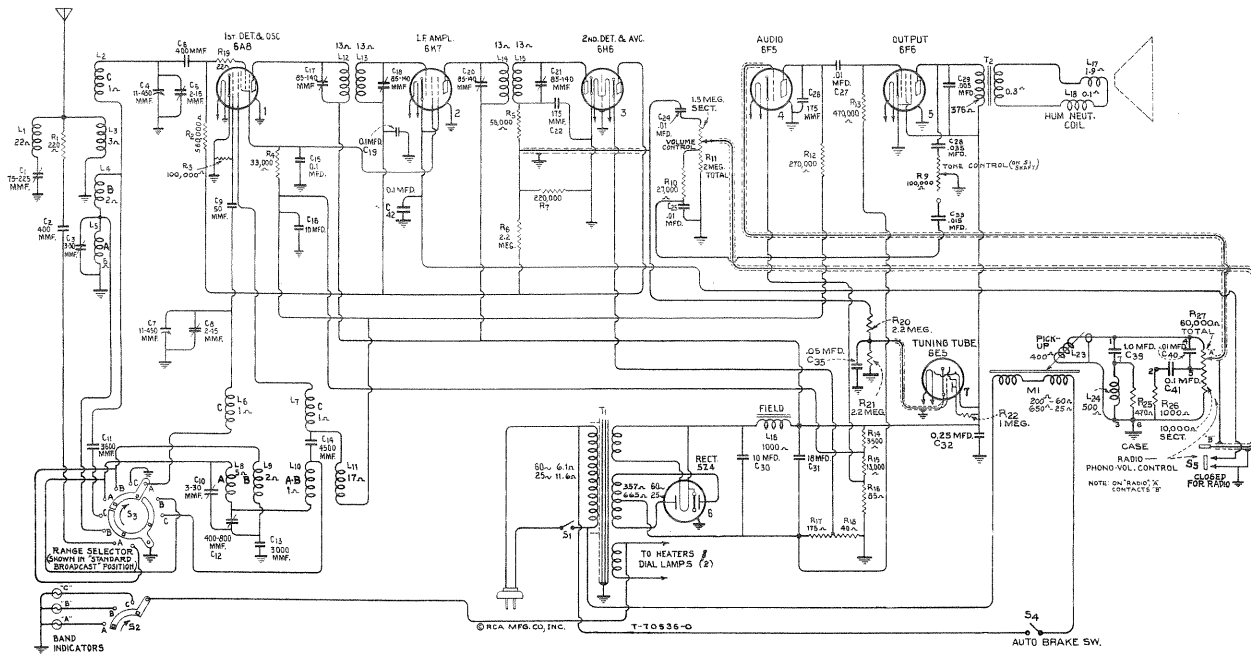

Figure 1—Schematic Circuit Diagram

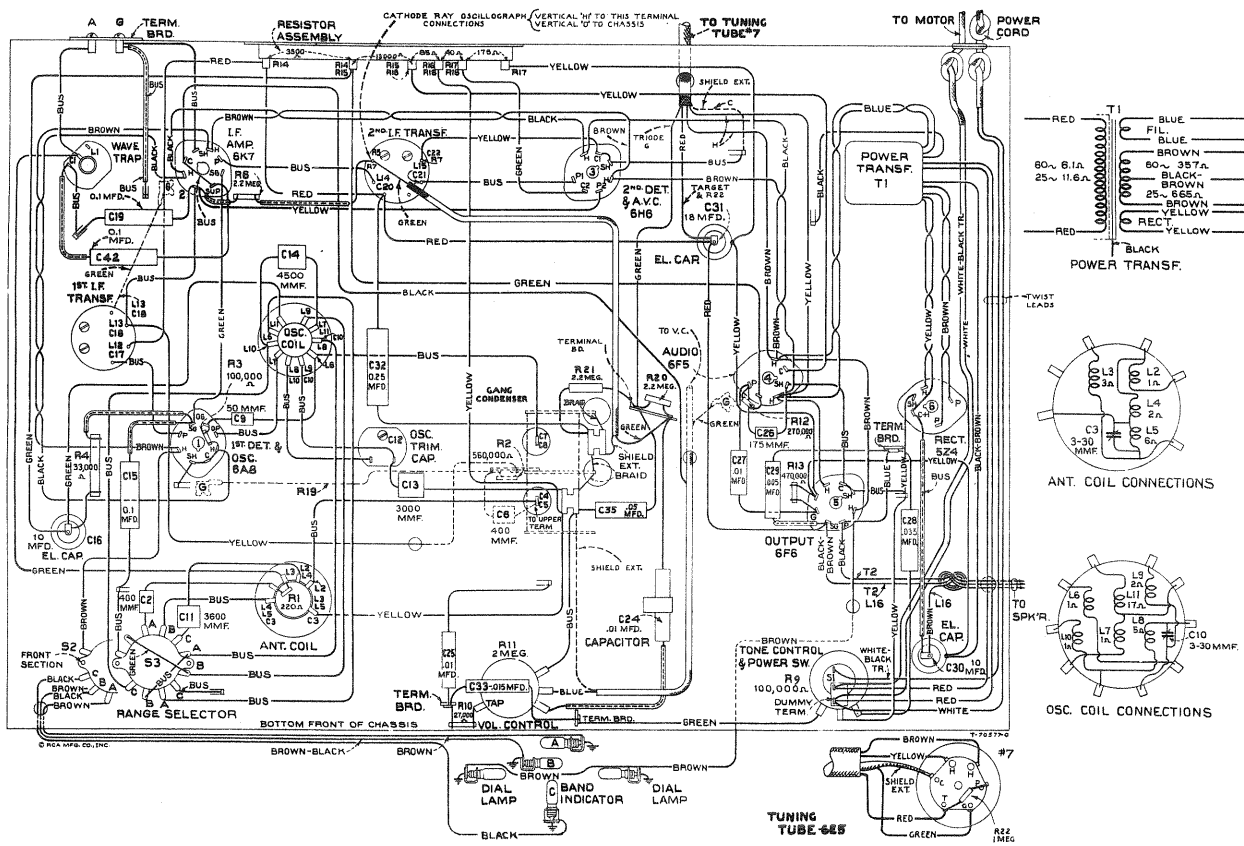

Figure 2—Chassis Wiring Diagram

lator coil system is similarly wound on a single form. A range-selector switch S3 is used for connecting the various sections of these two coil systems into the circuit to provide operation on the band desired. The coils are tuned by a variable two-section gang condenser having trimming capacitors in shunt with each section. There are additional trimming capacitors across the section of each coil used for the "Standard broadcast" band. A series trimming capacitor is also associated with the "Standard broadcast" oscillator coil.

The intermediate-frequency stage is coupled to the RCA-6A8 and to the RCA-6H6 by means of tuned transformers. The windings of these transformers (both primary and secondary) are resonated with adjustable trimming capacitors to tune to 460 kc.

The modulated signal as obtained from the output of the i-f system is detected by an RCA-6H6 twin-diode tube. Audio frequency secured by this process is passed on to the a-f system for amplification and final reproduction. The d-c voltage which results from detection of the signal is used for automatic volume control. This voltage which develops across resistor R7 is applied as automatic control-grid bias to the first detector and i-f tubes. The second (auxiliary) diode of the RCA-6H6 is used to supply residual bias for the controlled tubes under conditions of little or no signal. This diode, under such conditions, draws current which flows through resistors R6 and R7, thereby maintaining the desired operating bias on such tubes. On application of signal energy above a certain level, however, the auxiliary bias-diode ceases to draw current, and the a.v.c. diode takes over the biasing function.

Manual volume control is effected by means of an acoustically tapered potentiometer connected as a variable coupling element between the output of the second detector and the first-audio control grid. After amplification by the RCA-6F5, the audio signal is transmitted by resistance-capacitance coupling to the input of the RCA-6F6 power-output stage, which, in turn, is transformer-coupled to the dynamic loudspeaker.

Continuously-variable tone control is effected by means of the combination of a capacitor C28 and variable resistor R9 shunting the plate circuit of the output tube. Extreme clockwise rotation of the tone control disconnects the resistor R9 from the circuit and places an additional capacitor, C33, in shunt with capacitor C25, thereby reducing the low-frequency response of the amplifier. This point is known as the "Speech" position and provides optimum intelligibility of speech.

SERVICE DATA

Alignment Procedure

There are six adjustments required for the alignment of the antenna, oscillator, and wave-trap tuned circuits. The i-f transformer adjustments are made by four trimming capacitor screws. Improper alignment usually causes the impairment of sensitivity, selectivity, and tone quality. Such conditions will usually exist simultaneously.

An RCA-6E5 cathode-ray tuning tube is used as a means of visually indicating when the receiver is accurately tuned to the incoming signal. This tube consists of an amplifier section and a cathode-ray section, built in the same glass envelope. A component of the signal voltage developed across resistor R7 is used to actuate the control grid of the amplifier section.

The power-supply system consists of an RCA-5Z4 rectifier tube, which is supplied from an efficiently designed power transformer, and which works into a suitable filter. The various potentials required for the plate, screen, control grid, and cathode circuits, are obtained from the output of the filter. The electrodynamic loudspeaker field coil is used as a filter reactor.

The phonograph mechanism is of the manually operated type, having a synchronous motor which

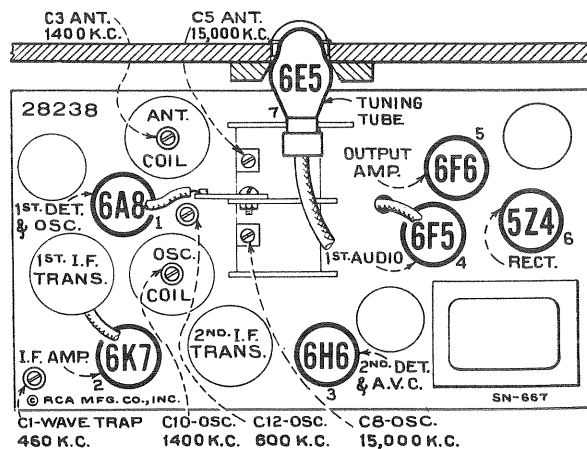

Figure 3—Radiotron, Coil, and Trimmer Locations

rotates the turntable at a speed of 78 r.p.m. The 10-inch turntable will accommodate either the 10-inch or 12-inch phonograph records. The pickup mechanism and tone arm are combined as one unit. The instrument may be purchased with any one of five ratings as specified under Electrical Specifications. *It is important that a machine of any particular rating be operated at the frequency and voltage for which it is rated.* Attempts to operate at ratings other than specified for the particular instrument will result in improper reproduction from the phonograph and may result in damage to both the phonograph motor and radio receiver. An automatic switch is provided to turn "off" the phonograph motor at the completion of the record.

A standard test oscillator, such as the RCA Stock No. 9595, will be required as a source of signal at the specified alignment frequencies. Means for indication of the receiver output during alignment is also necessary to show when the correct point of adjustment is reached. The RCA Stock No. 4317 Neon Glow Indicator is designed for this purpose.

Attach the output indicator across the loudspeaker

voice coil. Advance the receiver volume control to its maximum position, letting it remain in such position for all adjustments. For each adjusting operation, regulate the test-oscillator output control so that the signal level is as low as possible and still be observable at the receiver output. Use of such small signal will obviate broadness of tuning which would otherwise result from a.v.c. action on a stronger one.

I-F Adjustments

- Connect the test oscillator to the grid cap of the RCA-6A8 through a .001 mfd. capacitor, and connect the test oscillator ground to the receiver chassis. Set test oscillator to 460 kc.
- Adjust the two trimming capacitors (C20 and C21) of the second i-f transformer to produce maximum (peak) output.
- Adjust the two trimming capacitors (C17 and C18) of the first i-f transformer, to produce maximum (peak) output.

It is advisable to repeat the adjustment of all i-f trimming capacitors a second time to assure that the interaction between them has not disturbed the original adjustment.

R-F Adjustments

Calibrate the tuning dial by adjusting the scale pointer to the extreme end calibration mark (beyond 55 on dial) while the two-gang tuning condenser

plates are in full mesh. Alignment (see figure 3 for location of trimming adjustments) of "Wave-trap," "Short wave" band, and "Standard broadcast" band should be made in the following order and sequence.

"Wave-Trap"

- Connect the output of the test oscillator to the antenna terminal through a 200-mmfd. (important) capacitor, leaving the test oscillator ground connected to the receiver chassis. With the range selector in its "Standard broadcast" position, set the receiver dial to a position of no extraneous signals, near 600 kc (60 on dial). Set the test oscillator to 460 kc. Adjust the wave-trap trimming capacitor C1 to a point which causes minimum amplitude of output. An increase of the test oscillator output may be necessary before the point of minimum amplitude, obtained by adjustment of wave-trap screw, becomes apparent on the output indicator.

"Short Wave" Band

- Connect the output of the test oscillator to the antenna terminal through a 300-ohm resistor, leaving the test oscillator ground connected as before.
- Set the range selector to its "Short wave" position. Set receiver dial pointer to 15,000 kc (15 on dial). Adjust the test oscillator

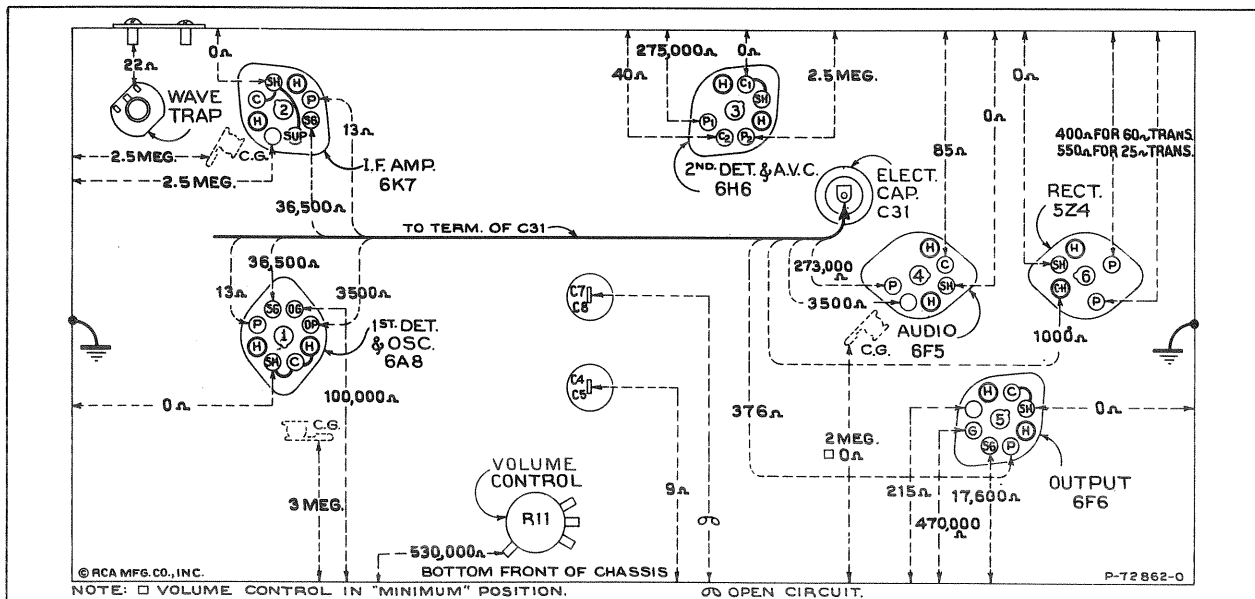

Figure 4—Resistance Diagram

Power supply disconnected—Radiotrons in sockets—Tuning condenser in full mesh
Range selector "Standard broadcast"—Radio-Phono-volume "Radio"—Radio volume control maximum

The resistance values shown between Radiotron socket contacts, grid caps, resistors, terminals, and receiver chassis ground, on figure 4, have been carefully selected so as to facilitate a rapid continuity check of the circuits. The use of this diagram in conjunction with the Schematic Circuit Diagram, figure 1, and Chassis Wiring Diagram, figure 2, will permit the location of certain troubles which might otherwise be difficult to ascertain. Each value as specified should hold within $\pm 20\%$. Variations in excess of this limit will usually be indicative of trouble in cir-

cuit under test. Resistance values were measured with Radiotrons in sockets, tuning condenser in full mesh, and volume control set at maximum except where otherwise noted. In all cases of measuring the resistance between points of the circuit and ground, it will be necessary to connect the negative terminal of the resistance meter to chassis-ground. If the polarity of the resistance meter is not known, it may be readily ascertained by connecting a d-c voltmeter of indicated polarity across the terminals of the device.

to 15,000 kc. Adjust the oscillator trimming capacitor C8 to the point which produces maximum (peak) output. Two points may be found, each of which produces a maximum. The one of maximum trimmer capacitance (most clockwise) is correct and should be used.

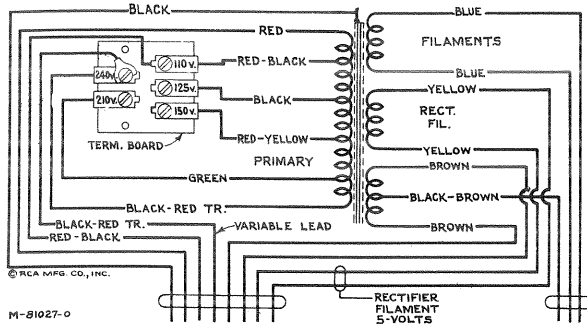

Primary Resistance—17.3 ohms total
Secondary Resistance—355 ohms total

Figure 5—Universal Transformer

- (c) Adjust the antenna trimming capacitor C5 of the variable condenser, simultaneously rocking the receiver tuning control backward and forward through the 15,000 kc input signal, until maximum (peak) output results from these combined operations.

"Standard Broadcast" Band

- (a) Connect the output of the test oscillator to the antenna terminal through a 200-mmfd. capacitor, leaving test oscillator ground connected as before.
- (b) Set the range selector to its "Standard broadcast" position. Set the receiver dial pointer

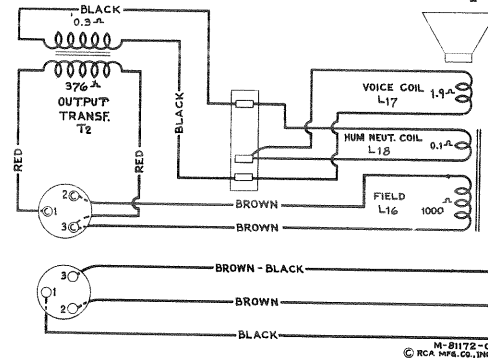

Figure 6—Loudspeaker Wiring

to 1,400 kc (140 on dial). Adjust the test oscillator to 1,400 kc. Adjust the oscillator and antenna trimming capacitors, C10 and C3 respectively, to the points where each produces maximum (peak) output.

- (c) Shift the test oscillator frequency to 600 kc and tune the receiver to pick up this signal,

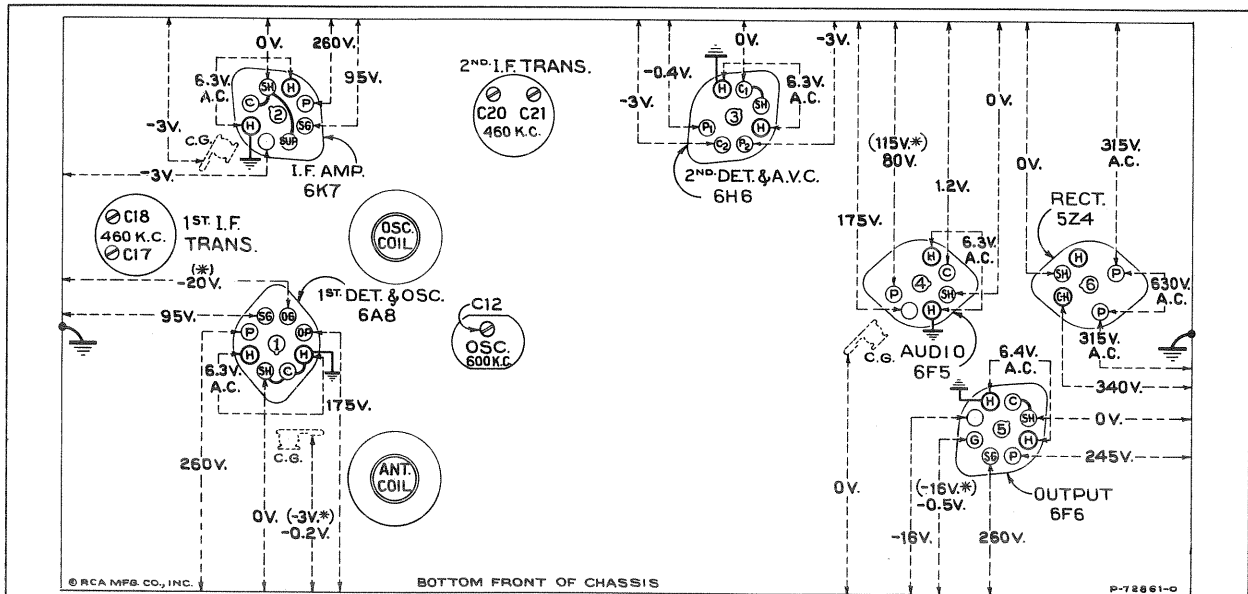

Figure 7—Radiotron Socket Voltages, Coil, and Trimmer Locations

Measured at 115 volts, 60-cycle supply—Tuned to approximately 1,000 kc "Standard broadcast" Radio-Phono-volume "Radio"—No signal being received—Volume control minimum

Note: Two voltage values are shown for some readings. The higher value shown in parentheses with asterisk (*) indicates operating conditions without voltmeter loading. The lower value is the actual measured voltage and differs from the higher value because of the additional loading of the voltmeter through the high series circuit resistance.

The voltage values indicated from the Radiotron socket contacts, grid caps, resistors, and terminals to receiver chassis ground on figure 7 will assist in locating cause of faulty operation. Each value specified should hold

within $\pm 20\%$ when the receiver is normally operative at its rated line voltage. Variations in excess of this limit will usually be indicative of trouble in the basic circuits. These voltages were measured with receiver tuned to approximately 1,000 kc, no signal being received, and volume control set at minimum. To duplicate the conditions under which the voltages were measured requires a 1,000-ohm-per-volt d-c meter, having ranges of 10, 50, 250, 500, and 1,000 volts. Use the nearest range above the voltage to be measured. A-c voltages were measured with a corresponding a-c meter.

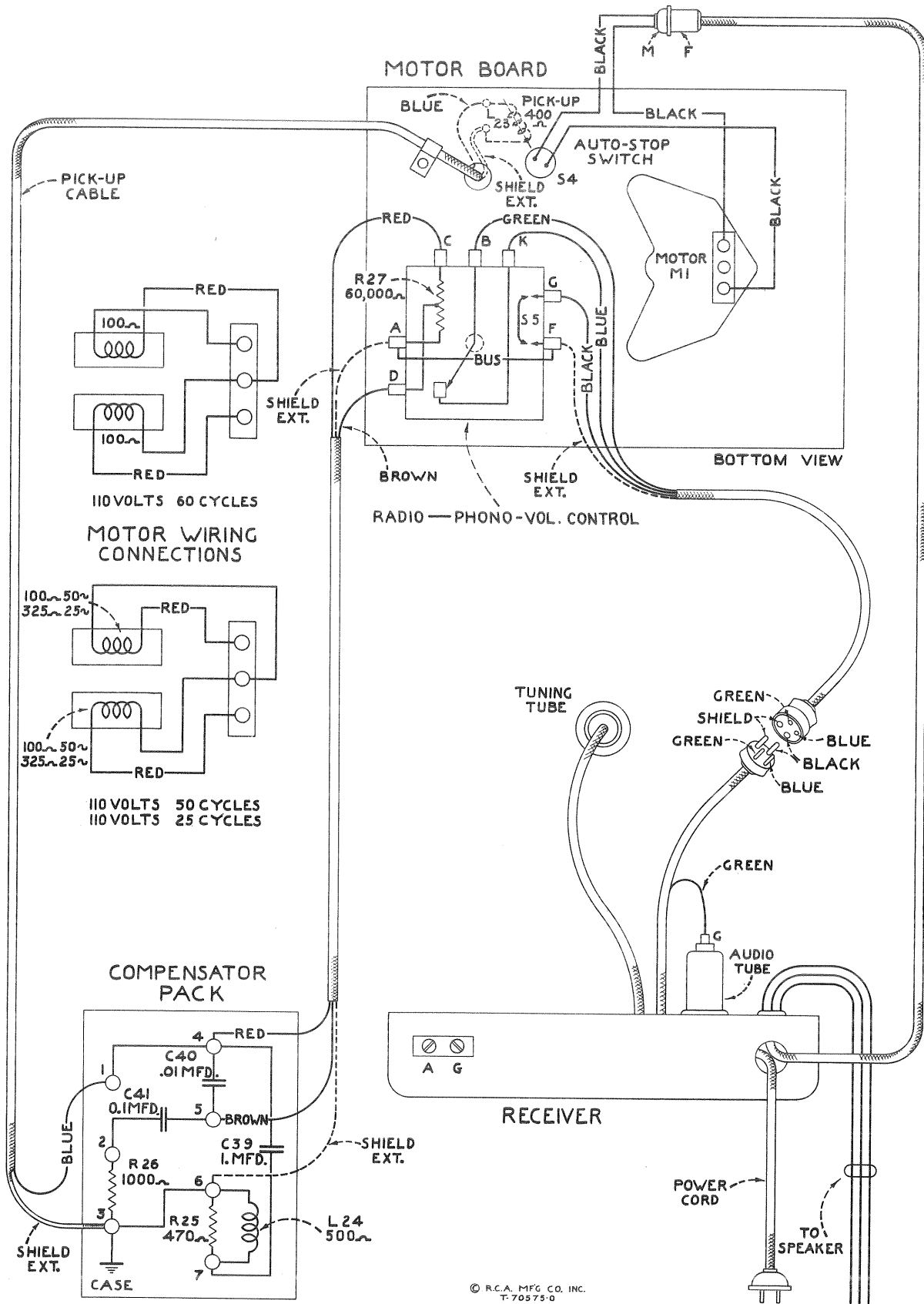

Figure 8—Assembly Wiring

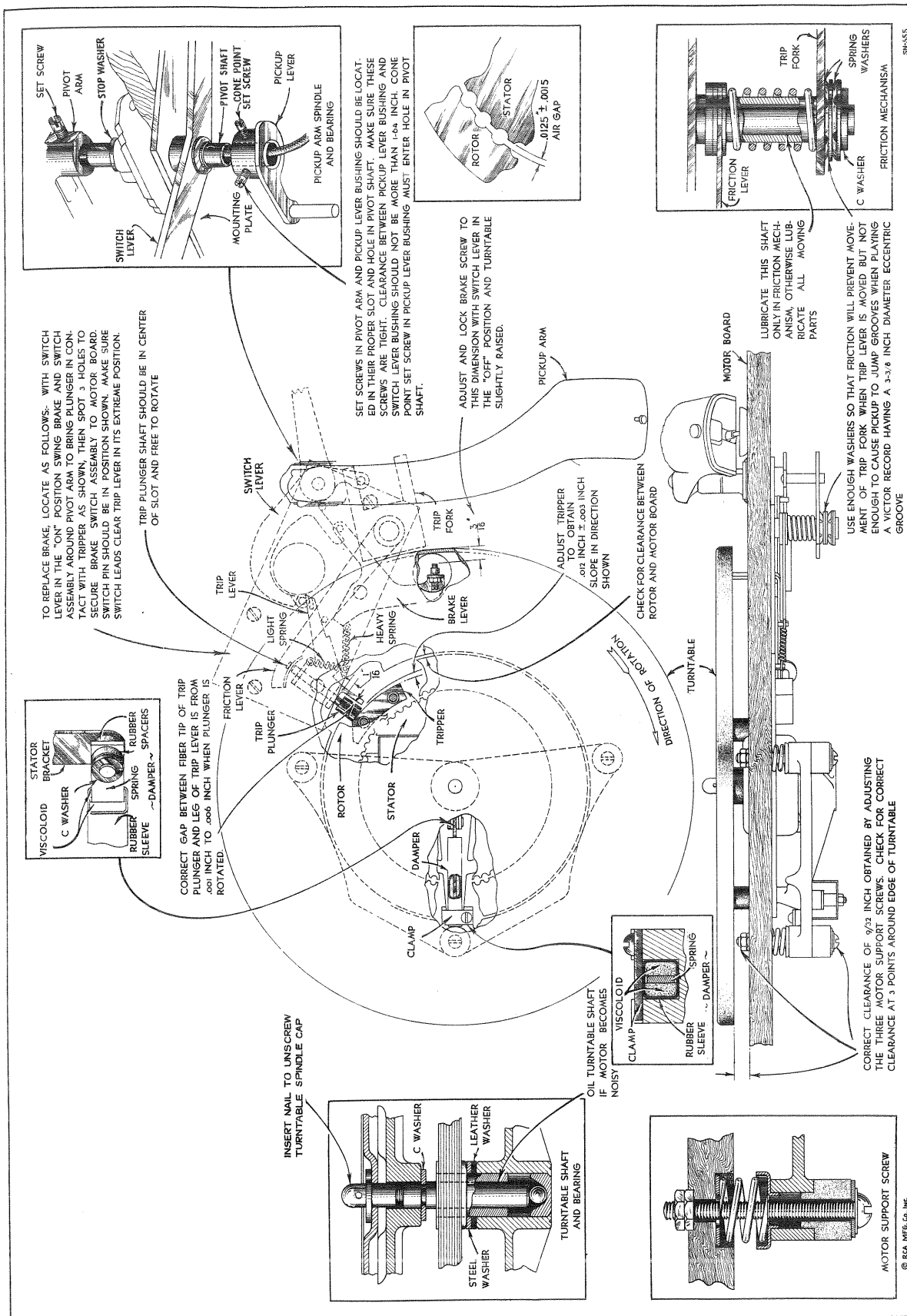

Figure 9—Motor Board Adjustments

disregarding the dial reading at which it is best received.

- (d) Adjust the low-frequency oscillator trimming capacitor, C12, simultaneously rocking the tuning control of the receiver backward and forward through the signal, until maximum (peak) output results from these combined operations. Repeat adjustments in (b) to compensate for any changes caused by the adjustment of the low-frequency oscillator coil trimming capacitor.

Phonograph Mechanism

The phonograph motor is of the synchronous type and designed to be simple and foolproof. Under normal operating conditions, service difficulties should

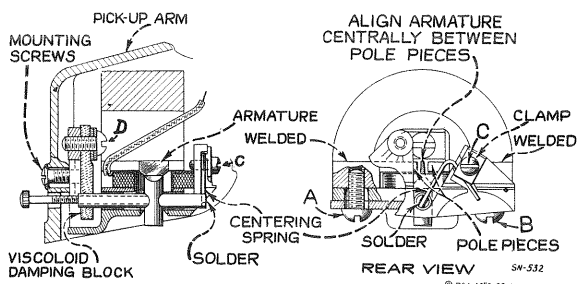

Figure 10—Details of Pickup

be negligible. Occasionally, however, certain adjustments may be required. These adjustments are illustrated and explained in figure 9.

Magnetic Pickup

The pickup used in the phonograph unit is of an improved design. The horseshoe magnet is rigidly welded to the pole pieces and is irremovable. There is a centering spring attached to the armature to maintain proper adjustment and to provide a limiting effect on the movement of the armature. The frequency response is substantially uniform over a wide range. Service operations which may be necessary on the pickup are as follows:

Centering Armature

Refer to figure 10 showing the pickup inner structure. The armature is shown in its proper relation to the magnet pole pieces, i. e., exactly centered. Whenever this centering adjustment has been disturbed it will be necessary to remove the pickup mechanism from the tone arm by removing the needle holding screw and the two mounting screws from the front of the tone arm, holding the pickup assembly to keep it from dropping. Unsolder the two leads from the lugs on the terminal board at the rear of the pickup. Insert a small rod or nail into the armature needle hole and replace the needle holding screw, tightening it to hold the rod securely. If the armature clamping screws A and B have not been disturbed, screw C should be loosened which will permit the armature to be moved from side to side, the rod acting as a lever to perform this operation. The proper adjustment is obtained when the armature is moved to the extreme position on each side (the movement being limited by the armature striking the pole pieces) and

then brought to the mid position between these two extremes. Screw C should then be tightened. The armature position should then be central between the pole pieces and at right angles to them. With a little practice, the correct adjustment of the armature will be obtained. The air gap between the pole pieces and the armature should be kept free from dust, filings, and other foreign material which would obstruct the movement of the pickup armature.

Damping Block

The viscoloid damping block which is attached to the front end of the armature shank serves as a mechanical filter to eliminate undesirable resonances and to cause the frequency response to be uniform. Should it be necessary to replace this damping block, the pickup mechanism should be removed from the tone arm as explained above. Unsolder the pickup coil leads from the two lugs on the pickup terminal board and remove the terminal board mounting screw and the terminal board. Then remove screw D and the damping block from the pickup assembly. Make sure that the shaft of the armature which contacts the viscoloid is clean. Then insert the new damping block so that it occupies the same position as that of the original block, and is in correct vertical alignment with the armature. The hole in the block is somewhat smaller than the diameter of the armature in order to permit a snug fit. With the damping block properly aligned on the armature, screw D with its washer should then be replaced. Heat should be applied to the armature (viscoloid side) so that the damping block will fuse at the point of contact and become rigidly attached to the armature. A special-tip soldering iron, constructed as shown in figure 11, will be found very useful in performing this operation. The iron should be applied only long enough to slightly melt the block, causing a small bulge on both sides.

Replacing Coil

Whenever there is defective operation due to an open or shorted pickup coil, this coil should be replaced. Remove the pickup mechanism and terminal board as described above. Remove screws A and B and the magnet assembly. Remove the bakelite coil support (with coil attached) and insert the new coil

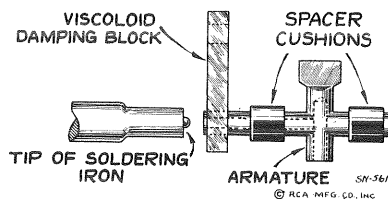

Figure 11—Special Soldering-Iron Tip

support assembly in its place, after which replace the magnet assembly and center the armature as described above, then re-assemble the remainder of the unit. Only rosin core solder should be used for soldering the coil leads and pickup leads to the pickup terminal board. This same type of solder should be used when necessary for soldering the centering spring to the armature.

Magnetizing

Loss of magnetization will not usually occur when the pickup has received normal care because the magnet and pole pieces are one unit and the magnetic circuit remains practically closed at all times. When the pickup has been mishandled, subjected to a strong a-c field, jolted, or dropped, there may be an appreciable loss of magnetic strength, in which case it will be necessary to remagnetize the entire structure. To

do this, it will be necessary to first remove the pickup mechanism from the tone arm, and then remove the magnet assembly. Place the magnet assembly on the poles of a standard pickup magnetizer such as the RCA Stock No. 9549 Pickup Magnetizer and charging the magnet in accordance with the instructions accompanying the magnetizer. It is preferable to check the polarity of the pickup magnet and to remagnetize it so that the same polarity is maintained.

REPLACEMENT PARTS

Insist on genuine factory tested parts, which are readily identified and may be purchased from authorized dealers

Stock No.	DESCRIPTION	List Price	Stock No.	DESCRIPTION	List Price
RECEIVER ASSEMBLIES					
12930	Board—Antenna and ground terminal board	\$0.20	11624	ohm, one 40-ohm and one 175-ohm sections—(R14, R15, R16, R17, R18)	\$0.95
5237	Bushing—Variable condenser mounting bushing assembly—Package of 3	.43	11620	Resistor—22 ohms—Flexible type complete with grid contact cap—(R19)	.22
11888	Cable—Tuning lamp cable and socket	1.06	11400	Resistor—220 ohms—Carbon type—1/10 watt—(R1)—Package of 5	.75
12032	Cable—3-conductor, shielded, volume control cable, approx. 8 inches long, complete with 4-contact male connector and grid contact cap	.90	8072	Resistor—27,000 ohms—Carbon type—1/4 watt—(R10)—Package of 5	1.00
11350	Cap—Grid contact cap—Package of 5	.20	11282	Resistor—33,000 ohms—Carbon type—1/2 watt—(R4)—Package of 5	1.00
12511	Cap—Grid contact cap—Package of 5	.15	11282	Resistor—56,000 ohms—Carbon Type—1/10 watt—(R5)—Package of 5	.75
11289	Capacitor—50 Mmfd.—(C9)	.25	12263	Resistor—100,000 ohms—insulated—1/4 watt—Package of 5—(R3)	1.00
11623	Capacitor—175 Mmfd.—(C22, C26)	.18	11398	Resistor—220,000 ohms—Carbon type—1/10 watt—(R7)—Package of 5	.75
11290	Capacitor—400 Mmfd. (C2, C6)	.25	11453	Resistor—270,000 ohms—Carbon type—1/10 watt—(R12)—Package of 5	.75
11622	Capacitor—3000 Mmfd.—(C13)	.36	11452	Resistor—470,000 ohms—Carbon type—1/10 watt—(R13)—Package of 5	.75
11621	Capacitor—3600 Mmfd.—(C11)	.38	11397	Resistor—560,000 ohms—Carbon type—1/10 watt—(R2)—Package of 5	.75
11287	Capacitor—4500 Mmfd.—(C14)	.30	12013	Resistor—1 megohm—Carbon type—1/10 watt—(R22)—Package of 5	.75
4868	Capacitor—.005 Mfd.—(C29)	.20	11626	Resistor—2.2 megohms—Carbon type—1/4 watt—(R6, R20, R21)—Package of 5	1.00
11315	Capacitor—.015 Mfd.—(C33)	.20	11603	Shield—Coil shield for Stock Nos. 11617 and 11618	.26
12670	Capacitor—.035 Mfd.—(C28)	.20	12735	Shield—Dial lamp shield—Package of 5	.25
11395	Capacitor—.01 Mfd.—(C24)	.18	11390	Shield—I. F. transformer shield for Stock Nos. 11388 and 11389	.25
4858	Capacitor—.01 Mfd.—(C25, C27)	.25	11199	Socket—Dial lamp socket	.14
4836	Capacitor—.05 Mfd.—(C35)	.30	12771	Socket—Dial lamp socket—Located at top of dial scale	.25
11414	Capacitor—.01 Mfd.—(C15, C42)	.20	11381	Socket—Tuning lamp socket and cover	.45
4841	Capacitor—.01 Mfd.—(C19)	.22	11195	Socket—5-contact 5Z4 Radiotron socket	.15
5170	Capacitor—.25 Mfd.—(C32)	.25	11198	Socket—7-contact 6F5 or 6H6 Radiotron socket	.15
11240	Capacitor—10 Mfd.—(C30)	1.08	11196	Socket—8-contact 6A8, 6F6 or 6K7 Radiotron socket	.15
11387	Capacitor—10 Mfd.—(C16)	.86	12769	Switch—Range switch—(S2, S3)	1.25
5212	Capacitor—18 Mfd.—(C31)	1.16	12668	Tone Control and Power Switch—(R9, S1)	1.22
11465	Capacitor—Adjustable trimmer—(C12)	.48	11391	Trap—Wave trap—(L1, C1)	1.22
11256	Capacitor—Adjustable trimmer for wave-trap, Stock No. 11391—(C1)	.48	11388	Transformer—First I. F. transformer less shield—(L12, L13, C17, C18)	1.90
11617	Coil—Antenna coil less shield—(L2, L3, L4, L5, C3, R1)	1.68	11389	Transformer—Second I. F. transformer less shield—(L14, L15, C20, C21, C22, R5, R7)	3.02
11618	Coil—Oscillator coil less shield—(L6, L7, L8, L9, L10, L11, C10)	2.22	11848	Transformer—Power transformer—100-125-volts, 50-60 cycles—(T1)	4.40
12767	Condenser—2-gang variable tuning condenser—(C4, C5, C7, C8)	4.10	11849	Transformer—Power transformer—100-125-volts, 25-40 cycles—(T1)	5.70
4573	Connector—2-contact female connector for motor cable—receiver section	.30	11850	Transformer—Power transformer—105-250-volts, 40-60 cycles—(T1)	8.00
5119	Connector—3-contact female connector for chassis reproducer cable	.25	13144	Volume control—(R11)	1.00
6123	Connector—4-contact male connector for cable, Stock No. 12032	.30			
12768	Drive—Variable tuning condenser vernier drive	1.30			
11619	Foot—Chassis mounting foot and bracket assembly—Package of 2	.65			
12770	Holder—Dial scale holder and lamp bracket assembly	.55			
12712	Indicator—Station selector indicator pointer	.22			
4340	Lamp—Dial lamp—Package of 5	.60			
12718	Mask—Dial light diffuser complete with red, orange and green-colored screen	.40			
11466	Resistor—Voltage divider—comprising one 3,500-ohm, one 13,000-ohm, one 85-				

The prices quoted above are subject to change without notice.

REPLACEMENT PARTS (Continued)

Stock No.	DESCRIPTION	List Price	Stock No.	DESCRIPTION	List Price
MOTOR BOARD ASSEMBLIES					
11751	Bushing—Motor mounting bushing and spring assembly, comprising one bushing, one large washer, one cup washer, one spring, one small washer and two nuts	\$0.25	11748	and laminations—105-125 volts, 25-cycle operation	\$3.08
13065	Lever—Brake mechanism actuating lever, fastens to pivot shaft under base	.20	11741	Damper—Motor damper assembly—comprising one damper, one damper plate, one screw, two rubber washers and one "C" washer	.20
3261	Rest—Pickup rubber rest—Package of 5	.40	11742	Motor—105-125 volts, 60-cycle motor complete—(M1)	11.10
11750	Screw—No. 4-40 x 9/32, cone pointed, headless set screw for lever, Stock No. 13065—Package of 10	.22	11743	Motor—105-125 volts, 50-cycle motor complete	11.10
AUTOMATIC BRAKE AND SWITCH ASSEMBLIES					
13099	Brake—Automatic brake and switch complete	4.90	11746	Motor—105-125 volts, 25-cycle motor complete	11.60
4577	Connector—2-contact male connector for brake switch power supply leads	.30	11746	Tripper—Automatic brake tripper—located on rotor laminations	.16
12932	Lever—Friction lever assembly complete	.35	11737	Turntable—Turntable assembly—complete with rotor laminations—60-cycle operation	4.80
11753	Plunger—Automatic brake trip plunger	.18	11738	Turntable—Turntable assembly—complete with rotor laminations—50-cycle operation	4.80
12043	Screw—Automatic brake screw and friction leather assembly	.20	11739	Turntable—Turntable assembly—complete with rotor laminations—25-cycle operation	5.05
11756	Spring—Automatic brake trip lever spring—Package of 10	.22	4083	Washer—Leather washer—Package of 10	.20
11757	Spring—Automatic brake lever spring—Package of 10	.20	4084	Washer—Metal washer—Package of 10	.26
11755	Switch—Automatic brake switch—(S4)	.75	MISCELLANEOUS ASSEMBLIES		
PICKUP AND ARM ASSEMBLIES					
11731	Armature—Pickup armature	.64	11762	Box—Used needle box	.25
11732	Coil—Pickup coil—(L23)	.60	11996	Bracket—Tuning lamp mounting bracket and clamp	.22
4543	Damper—Pickup damper block complete with damper plate	.10	12030	Cable—2-conductor shielded cable, approx. 18 inches long, connects phonograph volume control to compensator pack	.52
12931	Pickup and arm complete	7.50	12031	Cable—3-conductor shielded cable, approx. 19 inches long, complete with 4-contact female connector, connects phonograph volume to receiver	1.04
11951	Screw—Needle holding screw—Package of 10	.46	11272	Clamp—Cable clamp for phonograph volume control cable, Stock Nos. 12030 and 12031—Package of 5	.10
REPRODUCER ASSEMBLIES					
11232	Board—Terminal board assembly	.18	11760	Compensator—Phonograph compensator pack, comprising one 470-ohm and one 1,000-ohm resistors, one .01 Mfd., one .1 Mfd. and one 1 Mfd. capacitors and one .25 Henry reactor—(L24, C39, C40, C41, R25, R26)	3.85
11231	Bolt—Yoke and core assembly bolt and nut	.16	4153	Connector—4-contact female connector for cable, Stock No. 12031	.48
8060	Bracket—Output transformer mounting bracket	.14	12666	Cover—Reproducer cover	.65
11257	Clamp—Cone center suspension clamping nut and screw assembly—Package of 5	.25	12698	Escutcheon—Station selector escutcheon and crystal	1.02
11470	Coil—Field coil—(L16)	2.16	12742	Escutcheon—Tuning tube escutcheon	.22
11469	Neutralizing coil—(L18)	.20	11347	Knob—Phonograph volume control, receiver volume control, or range switch knob—Package of 5	.75
11258	Cone—Reproducer cone—(L17)—Package of 5	3.85	11610	Knob—Station selector knob—includes one large and one small knob—Package of 5	1.00
5118	Connector—3-contact male connector for reproducer	.25	11582	Knob—Tone and power switch knob—Package of 5	.50
5119	Connector—3-contact female connector for reproducer cable	.25	11763	Receptacle—Needle receptacle	.38
9622	Reproducer complete	7.16	11210	Screw—Chassis mounting screw assembly—comprising one screw, one washer, and one lockwasher—Package of 4	.28
11253	Transformer—Output transformer—(T2)	1.56	4982	Spring—Retaining spring for large knob in Stock No. 11610—Package of 10	.50
11886	Washer—Spring washer used to hold field coil securely—Package of 5	.20	11349	Spring—Retaining spring for small knob in Stock Nos. 11610, 11347 and 11582—Package of 5	.25
MOTOR ASSEMBLIES					
10194	Ball—Steel ball bearing—Package of 20	.25	11695	Volume Control—Phonograph volume control and switch—(R27, S5)	1.60
11740	Base—Motor base and bearing assembly	1.45			
11745	Cap—Turntable spindle cap—Package of 5	.30			
11733	Coil—Stator assembly—comprising coil and laminations—105-125 volts, 60-cycle operation	2.96			
11734	Coil—Stator assembly—comprising coil and laminations—105-125 volts, 50-cycle operation	3.08			
11735	Coil—Stator assembly—comprising coil				

First Edition.

The prices quoted above are subject to change without notice.